



## XGC400-I Crawler Crane Technical Specification

**Crawler crane model: XGC400-I**

**Max. rated lifting capacity: 400t**

**Max. load moment: 5200 t.m**

### I. Product component and system description

#### 1. Boom combinations

The boom sections of XGC400-I crawler crane use high-strength seamless pipe as the chords and lacing members, supplemented by four-chord lattice structure which is welded by high strength steel plate, with equal section in the middle and variable section at two ends.

##### 1) Standard working condition

①HB: Heavy boom in standard working condition, length 24~84m, composition: 10.5m boom butt×1, 6m boom insert×2, 12m thick-wall boom insert I×1, 12m thick-wall boom insert II×1, 12m thin-wall boom insert×2, 6m transition section×1, 6m light boom section×1, 1.5m boom head ×1, boom head sheave block ×1.

②LB: Light boom in standard working condition, length 42~108m, composition: 10.5m boom butt×1, 6m boom insert×1, 12m thick-wall boom insert I×1, 12m thick-wall boom insert II×1, 12m thin-wall boom insert×2, 6m boom transition section×1, 6m tower jib insert I ×1, 6m tower jib insert II ×1, 12m thick-wall tower jib insert×1, 12m thin-wall tower jib insert×1, 7.5m tower jib top×1.

③HW: Heavy boom + tower jib, boom length 30~60m, tower jib length 24~72m, tower jib composition: 10.5m tower jib butt×1, 6m tower jib insert I ×1, 6m tower jib insert II ×2, 12m thick-wall tower jib insert×1, 12m thin-wall tower jib insert×1, 12m tower jib center hitch section×1, 7.5m tower jib top ×1.

④HF: Fixed jib working condition. Fixed jib can be installed when boom length is 24~78m. Fixed jib length is 9m.

⑤HJ: Heavy boom + goose head jib (optional configuration), goose head jib can be installed when boom length is 66m~84m. Goose head jib is composed of 0.8m connection section and 8m goose head jib top section.



⑥HFS: TBM jib (optional configuration), boom length 24m, jib length 9m.

## 2) Superlift working condition

①SHB: Superlift heavy boom, 36~84m, heavy boom combination is the same as that in standard working condition. Customers can choose an additional 12m boom insert (option) to make the total boom length reach 96m.

②SLB: Superlift light boom, 72~126m, composition: 10.5m boom butt×1, 6m boom insert ×2, 12m thick-wall boom insert I×1, 12m thick-wall boom insert II×1, 12m thin-wall boom insert×2, 6m boom transition section×1, 6m tower jib insert I×1, 6m tower jib insert II ×2, 12m thick-wall tower jib insert×1, 12m thin-wall tower jib insert×1, 7.5m tower jib top×1.

③SHW: Superlift heavy boom + tower jib, heavy boom length 36~84m, tower jib length 24~84m, tower jib composition: 10.5m tower jib butt×1, 6m tower jib insert I×1, 6m tower jib insert II ×2, 12m thick-wall tower jib insert×1, 12m thin-wall tower jib insert×2, 12m tower jib center hitch section×1, 7.5m tower jib top ×1.

④SHJ: Superlift heavy boom + goose head jib (optional configuration), goose head jib can be installed when boom length is 78m~96m. Goose head jib is composed of 0.8m connection section and 8m goose head jib top section.

⑤SHFS: Superlift TBM jib (optional configuration), boom length is 36m, and jib length is 9m.

## 2. Turntable

Turntable is a box frame structure and welded by high strength steel plate. The overall structure is a large box frame with equal strength, the I-shaped main vertical plates at left and right sides are connected with box beam. This structure is with strong bending and torsion resistance and good stability. At the same time, the space in turntable is large, which is convenient for crane maintenance. Turntable is connected to undercarriage through slewing bearing. Many important parts are installed on turntable, such as operator's cab, main luffing winch, main and aux. hoist winches, engine, mast, turntable counterweight and boom system.

## 3. Pendant

High strength pendant structure, it is composed of two groups of pendant. The pendant is made of high strength steel with high safety factor. The pendant is equipped with a balance beam, which can effectively balance the load on the two pendant groups, so that the force is uniform.



#### 4. Mast

Standard mast is box-type structure of twin tubular chord, with good overall stability. The mast is equipped with mast raising mechanism and mast installation power pin. Auxiliary assembly cylinder is fitted to realize the self-assembly/disassembly function of track frame, center counterweight and boom. The mast can be transported with main luffing mechanism.

Superlift mast uses high strength seamless pipe as the chord and lacing members, supplemented by four-chord lattice structure which is welded by high strength steel plate, with equal section in the middle and variable section at two ends. The length of superlift mast is 30m, including one bottom section, one 6m section, one 12m section and one top section. The superlift mast is equipped with automatically controlled hydraulic backstop device.

#### 5. Mechanism composition

See the following table for the configuration and use of the mechanisms of the crane.

No.	Mechanism name	Use	Position
1	Main hoist winch	Used for the lifting operation of boom, fixed jib and tower jib	Turntable
2	Aux. hoist winch	Used for the lifting operation of boom, fixed jib and tower jib	Turntable
3	Boom luffing winch	Used for boom luffing operation	Turntable
4	Tower jib luffing winch	Used for tower jib luffing operation and single top lifting operation	Boom base
5	Superlift luffing winch	Used for superlift boom luffing operation	Superlift mast butt. section
6	Slewing gear	Used for superstructure slewing	Turntable
7	Travel gear	Used for crane travel	Crawler track
8	Reeving winch	Assist the reeving of wire rope	Turntable

#### 6. Hoist winch

Main and aux. winches have the same model and driven independently. They can work synchronously for heavy load lifting. Hoist winches adopt constant-closed disc brake, built-in



reducer and variable displacement drive motor. The two winches use box frame, hydraulic power pin is used to connect them to turntable.

The wire ropes are all rotation resistance. For main hoist winch, rope diameter  $\phi 28$  mm; for aux. hoist winch, rope diameter  $\phi 28$  mm.

### **7. Luffing winch**

Boom luffing winch is twin drum form. Ratchet lock device, built-in reducer and constant-closed disc brake are adopted for this system, rope diameter  $\phi 26$  mm.

Tower jib luffing winch adopts ratchet lock device, built-in reducer and constant-closed disc brake, rope diameter  $\phi 26$  mm.

Superlift luffing winch adopts ratchet lock device, built-in reducer and constant-closed disc brake, rope diameter  $\phi 26$  mm.

### **8. Slewing gear**

Slewing gear is arranged in front of turntable, two planetary reducers are used to make it externally meshed with slewing bearing, with hydraulic buffering and free swing function. Constant-closed disc brake is used; it is reliable in work and easy for maintenance.

### **9. Slewing bearing**

The three-row roller type slewing bearing are externally meshed, with features of high strength, large bearing torque and easy maintenance.

### **10. Oil cylinder assembly**

The connection between boom and turntable, the connection between car-body and track frame, the installation of hoisting winches and the installation of main luffing mechanism are all realized by the use of hydraulic power pin. This crane is equipped with mast raising cylinder, mast derrick cylinder, car-body outrigger cylinder, track tension cylinder and etc., the operator's cab is also set with cab tilting cylinder and cab rotation cylinder.

### **11. Operator's cab**

Operator's cab is steel frame structure. The front is equipped with integral laminated glass, while others are tempered glass. The cab is equipped with adjustable seat, all kinds of ergonomic designed instruments and controls, vent type air conditioner, stereo, fire extinguisher,



and closed circuit monitoring system, spacious and comfortable.

When the crane is in operation, the cab can be tilted upward to widen the field of vision. When the crane is in transport, the cab can be turned to the front side to reduce the transport width.

## **12. Car-body**

Car-body is made of high strength steel plate and welded in box type structure. Cross panel is set in the middle to strengthen its torsion stiffness, simple structure, high load bearing capacity and good rigidity.

## **13. Crawler travel device**

Crawler track consists of crawler beam, drive sprocket, idler wheel, upper roller, lower roller and track shoe. Crawler beam is box-shape structure, its connection part with car-body is strengthened partially, and cross panel is installed in the middle of it. The rollers and track shoes are all made of high strength alloy cast steel.

The two track frames are set symmetrically, installed with crawler shoes of 1.2m in width. They can be operated synchronously or separately to realize straight travel and turning. Four-wheel-drive travel reducer, built-in planetary gear reducer and variable displacement motor drive.

## **14. Hydraulic system**

It adopts electric proportional pilot variable pump control system, with combination of open and closed circuit, the system is stable with good speed adjustment.

Hoist system, luffing system and travel system are all open pump control systems, main luffing system is with dual pump confluence function.

Slewing system is closed pump control system, with a special slewing buffer valve; the transmission is stable without impact.

For main hoist, aux. hoist and travel systems with large speed regulation range, variable motor drive is adopted. The combination of variable motor and variable pump control system can achieve accurate control of the movement speed, with good fine motion performance.

## **15. Electrical system**

Electrical system mainly includes the following parts: engine control, monitoring instruments,



auxiliary equipment, hydraulic system control, load moment limit and safety monitoring, etc.

Composition of electrical system: conventional electrical system and PLC control system.

The conventional electrical system adopts 24V parallel circuit, and the wiring of all electric equipments adopts single wire system, negative earth. It includes power supply, starting control, engine control and status monitoring, cab air conditioner and stereo, illumination (lighting), wipers, walkie talkies, etc.

The PLC control system includes the control of hoisting, luffing, slewing, travel and the rotation and tilting of operator's cab. All movements adopt electro-hydraulic proportional control technology and controlled through PLC logic, which can effectively guarantee the realization of all functions of the crane.

## **16. Engine system**

Model: Weichai WP12.460N;

Rated power: 338 kW/1900rpm;

Max. torque/max. torque speed: 2110Nm/1400rpm;

Structure type: 6-cylinder in line, water-cooling, turbocharged and inter-cooled, and electronic injection, four-stroke diesel engine.

Emission standard: comply with the standard of Euro III or China III;

Fuel tank capacity: 750L.

## **17. Counterweight**

Counterweight system includes car-body counterweight, turntable counterweight and superlift counterweight.

Car-body counterweights are installed on track frame, its self-assembly/disassembly is realized through the use of mast derrick. Car-body counterweight is 40t in total, composition: car-body counterweight 2×20t.

Turntable counterweights are installed on turntable rear side, three configurations of 110t, 130t and 150t are shown as follows:

(1) 110t: counterweight box 2×15t, counterweight slab 8×10t;

(2) 130t: counterweight box 2×15t, counterweight slab 10×10t;



(3) 150t: counterweight box  $2 \times 15\text{t}$ , counterweight slab  $12 \times 10\text{t}$ ;

Superlift counterweight is 230t in total, the composition is as follows:

Superlift counterweight tray  $1 \times 10\text{t}$ , counterweight slab  $22 \times 10\text{t}$  (4 counterweight slabs are borrowed from turntable counterweight).

### 18. Hook block

There are 6 kinds of hook blocks, the configurations are as follows:

Name	400t	350t	260t	160	50t	16t
Weight (t)	6.8	6.2	4.6	3.9	2.5	0.9
Configuration	Optional configuration	Standard configuration				

### 19. Centralized lubrication system

The use of progressive centralized lubrication system is controlled by computer programming. It can add lubricating oil automatically point by point, so as to ensure that each point is lubricated sufficiently and make crane maintenance more easy and convenient.



## **II. Safety Protection Measures**

The safety protection functions of this crane are as follows: Assembly mode & working mode exchange function, emergency stop function, LMI system, hydraulic system safety protection function, rope over-wind protection function, rope over-release protection function, anti-misoperation function, ratchet locking function, slewing locking function, boom backstop function, boom angle limit function, hook latch, hoist height limit function, video monitoring function, sound and light alarm function, lightning protection function. At the same time, it is equipped with illuminator light, rearview mirror, height mark lamp, anemometer, gradienter and etc.

### **1. Assembly mode & working mode changeover switch**

In Assembly mode, over-wind protection device, boom angle limiter and load moment limiter are all out of service, in order to facilitate crane assembly; in working mode, all safety devices work normally.

### **2. Emergency stop function**

This crane has emergency stop function, all crane movements can be stopped quickly in case of emergency.

### **3. LMI system**

Detection function: LMI can automatically detect parameters such as boom angle and lifting weight.

Display function: 10.4-inch high-definition LCD display, show important parameters in





lifting operation through text and graphics, such as load moment percentage, actual lifting weight, rated lifting weight, radius, boom length, angle, maximum lifting height, working condition code, parts of line, limit angle and information code.

Warning function: with complete pre-alarm and overload stop function. If it is detected that the actual weight exceeds the rated lifting capacity or boom angle exceeds the maximum value, LMI will send alarm and limit the current movement of the crane.

The system has self-diagnosis function.

#### **4. Hydraulic system safety protection function**

Hydraulic system is equipped with hydraulic balance valve, hydraulic relief valve and other devices to ensure the stable and safe work of the system.

#### **5. Rope over-wind protection function**

There is an over-wind protection device on boom head to prevent rope from being over-wound. When main/auxiliary winch hoists up to a certain lifting height, the over-wind warning light on display will be on, and load moment limiter will stop hoisting up movements at the same time.

#### **6. Rope over-release protection function**

Rope end limiter is set on each hoist winch to prevent wire rope from over-releasing. When there are only three loops of rope left on winch, the over-release warning light on display will be on, and the movement of lowering down will be stopped at the same time.

#### **7. Anti-misoperation function**

The handles have anti-misoperation function. A safety protection switch is set at the front of the handle. If the switch is not pressed, all movement signals are shielded, and the handle will not work to prevent operation error.

#### **8. Ratchet locking function**

Ratchet locking device is used to lock the luffing winch so that boom is stopped and placed safely at non-working state.

#### **9. Slewing locking function**

Slewing locking device is used to lock superstructure slewing when the crane is stopped.

#### **10. Backstop function**



Main boom, superlift mast, tower jib and tower jib struts are equipped with backstop devices to prevent boom from tilting backward.

### **11. Boom angle limit function**

In working mode, when boom is elevated to the max. working angle, boom raising will be stopped under the control of load moment limiter and hoist limit switch; when boom is elevated to the min. working angle, boom lowering will be stopped under the control of load moment limiter, and a sound warning will be given. The upper and lower limits of tower jib are controlled by angle limit switch.

### **12. Hook latch**

All lifting hooks are equipped with latch to prevent the suspended rope on the hook head from falling off.

### **13. Hoist height limit function**

Suspended height limit device is installed on boom head, when the hook contacts the height limit device, the lifting movement will be stopped to avoid damage to the wire rope.

### **14. Closed circuit monitoring system**

The system is composed of camera and monitor. It is used to monitor the hoist winches, boom luffing winch, jib luffing winches and etc.

### **15. Sound and light warning function**

It is equipped with tri-color warning light and audio/video alarm. It can display the load and movement status of the vehicle, flash the lights and send sound alarm to alert the driver and people outside the vehicle.

### **16. Lightning protection function**

Lightning protection grounding system and surge protector system are optionally configured for this crane to reduce lightning strike possibility of the control system.

### **17. Illuminator light**

There are illuminator lights in front of turntable, above the cab and inside the cab for lighting.

### **18. Rearview mirror**



It is outside the operator's cab so that the driver can observe the situation behind the machine.

### **19. Height mark lamp**

It is located on boom tip for high level operation warning.

### **20. Anemometer**

It can detect the current wind speed and send signal to the monitor in operator's cab to remind the operator for safe operation in wind load.

### **21. Gradiometer**

It is equipped with electronic and mechanical gradiometers, which can show the ground gradient and provide reference for the operator.



### III. Main parts list

No.	Part Name		Model	Manufacturer	
1	Engine system	Engine	WP12	Weichai Power	
		Air filter	NLG37-32	MANN+HUMMEL	
		Muffler	1740-XYQ	Danyang Changjiang	
		Radiator	LQXT.042	Xuzhou Yinlun	
		Transfer case (with shaft coupling)	TPYE4382	STIEBEL(Germany)	
2	Hydraulic system	Main hoist winch	Reducer	ZFT110	Zhuzhou Gear
			Motor	A6VM200	Rexroth
		Aux. hoist winch	Reducer	ZFT110	Zhuzhou Gear
			Motor	A6VM200	Rexroth
		Main luffing winch	Reducer	ZFT80	Zhuzhou Gear
			Motor	A2FE125	Rexroth
		Tower jib luffing winch	Reducer	ZFT110	Zhuzhou Gear
			Motor	A6VM200	Rexroth
		Superlift luffing winch	Reducer	ZFT110	Zhuzhou Gear
			Motor	A6VM200	Rexroth
		Slewing	Reducer	ZFB60	Zhuzhou Gear
			Motor	A2FE80	Huade Hydraulic
		Travel	Reducer	CMWG360	Dalian Huarui
			Motor	A6VE160	Rexroth
Main pump			A11VLO145	Rexroth	
Main valve			M7	Shengbang	
3	Electrical control system	LMI	IFLEX5	Wika	
		Tension sensor	KMD130T	Wika	
		Display	ICP6660	Wika	
		Controller	IFLEXC3	Wika	
		Electronic level meter	——	SINOCOM	
		Lightning protection system	——	PHOENIX	
		Black box	——	Wika	



No.	Part Name		Model	Manufacturer
	Beacon warning light		—	Nanhua
	Angle sensor		—	Wika
	Height limit switch		—	Wika
	Operating handle		—	P+G
	Closed circuit monitoring system	Monitor	—	Aokaipu
		Camera	—	Aokaipu
4	Slewing bearing		131.40.2600	Xuzhou Rothe Erde
5	Operating equipment	Boom main chord	BG890QL	Shanghai Baosteel
		Tower jib main chord	BG890QL	Shanghai Baosteel
		Fixed jib main chord	BG890QL	Shanghai Baosteel
6	Wire rope	Main hoist rope	Φ28, L=800	Junwei
		Aux. hoist rope	Φ28, L=800	Junwei
		Main luffing rope	Φ26, L=520	Junwei
		Tower jib luffing rope	Φ26, L=520	Junwei
		Superlift luffing rope	Φ26, L=790	Junwei
7	Hook	Standard configuration	350t/260t/160t/50t/16t	Shandong Hongruida/ Xuzhou Dachangshi
		Optional configuration	400t	
8	Travel system	Drive sprocket		Jining Yongsheng
		Guide roller		Jining Yongsheng
		Upper roller		Jining Yongsheng
		Lower roller		Jining Yongsheng
		Track shoe		Liyang Yongheng

Note: Due to different manufacturers, the model of the parts will also be different.



## **IV. Main Technical Parameters**

### **1. XGC400-I crawler crane outline dimension**

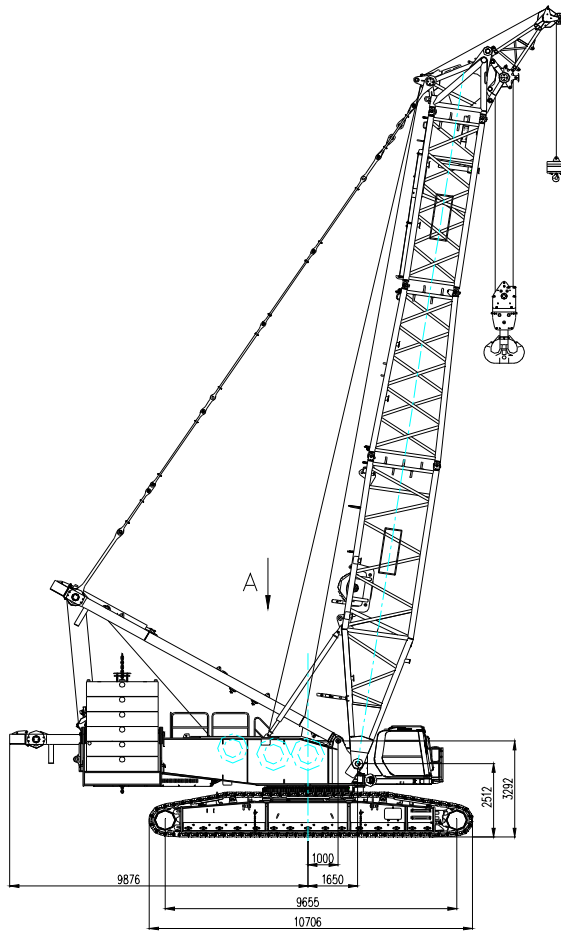

Remove boom, mast and etc.

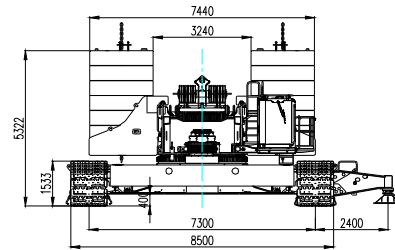

A direction (remove boom, mast and etc.)

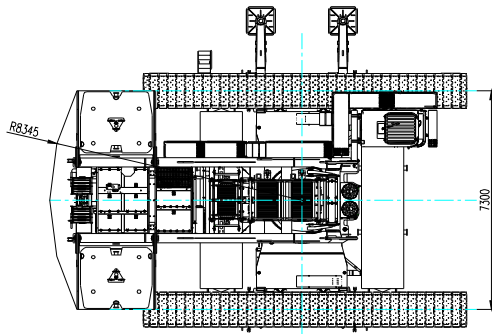

Fig. 1 XGC400-I crawler crane outline dimension (standard working condition)

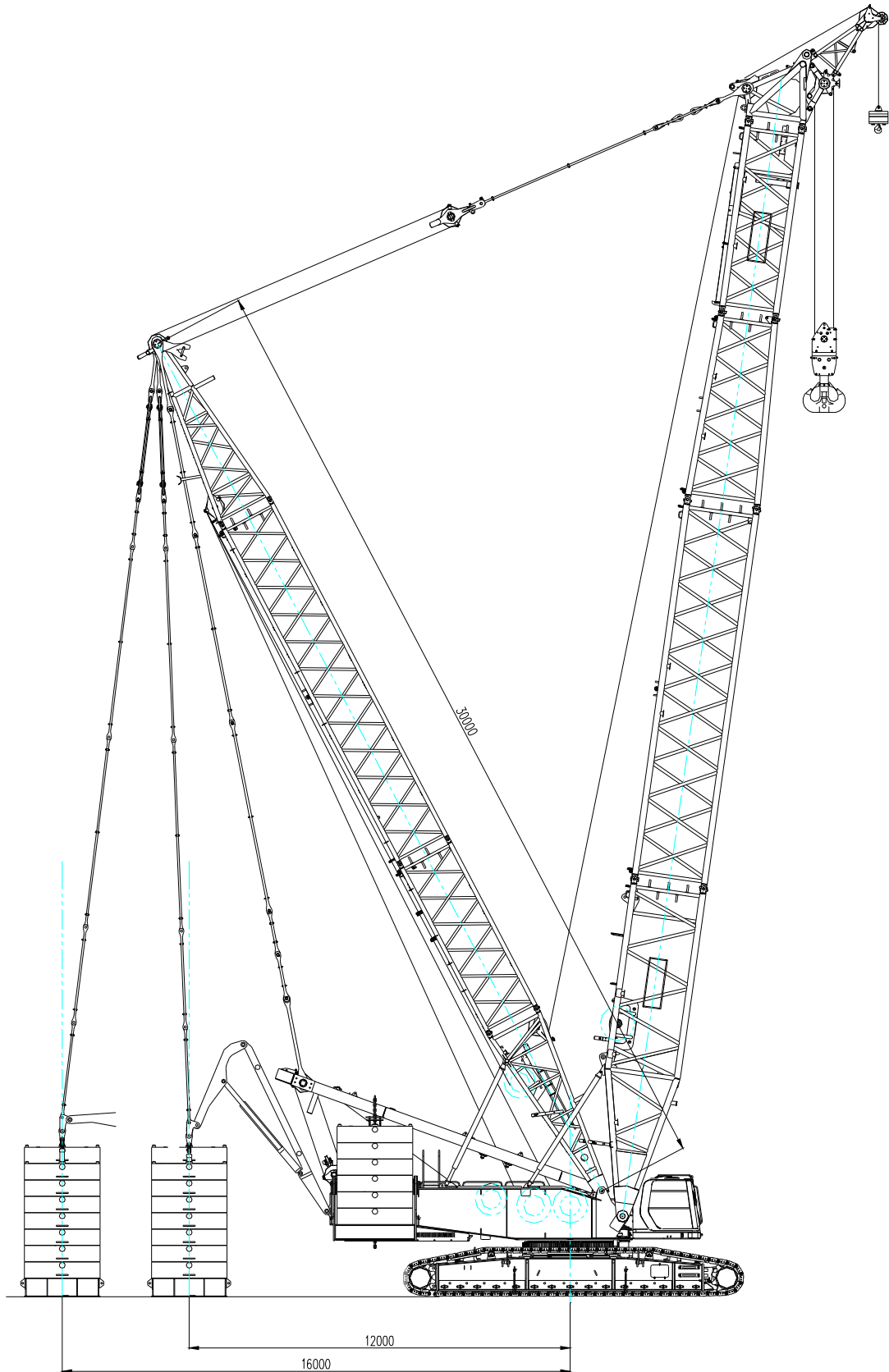

Fig. 2 XGC400-I crawler crane outline dimension (superlift working condition)



**2. XGC400-I crawler crane technical parameters**

		<b>Item</b>	<b>Unit</b>	<b>Data</b>
Max. rated lifting capacity	Standard working condition	Heavy boom	t	400
		Light boom	t	220
		Tower jib	t	150
		Fixed jib	t	200
		TBM jib	t	350 (main hook), 185 (aux. hook)
		Goose head jib	t	119
	Superlift working condition	Heavy boom	t	400
		Light boom	t	220
		Tower jib	t	220
		TBM jib	t	400 (main hook), 185 (aux. hook)
		Goose head jib	t	116
Max. lifting moment	Standard working condition		t.m	2600
	Superlift working condition		t.m	5200
Dimension	Standard working condition	Heavy boom length	m	24~84
		Light boom length	m	42~108
		Tower jib length	m	24~72
		Fixed jib length	m	24~78+9
		Fixed jib angle	°	10°
		TBM jib length	m	24+9
		Goose head jib length	m	66~84+7
	Superlift working condition	Heavy boom length	m	36~84 (option: 96)
		Light boom length	m	72~126
		Tower jib length	m	24~84



		TBM jib length	m	36+9
		Goose head jib length	m	78~84(option: 96)+7
Speed		Hoist winch max. single line speed	m/min	130
		Boom luffing winch max. single line speed	m/min	2×51
		Tower jib luffing winch max. single line speed	m/min	100
		Superlift luffing winch max. single line speed	m/min	105
		Max. slewing speed (no load)	rpm	1.16
		Max. travel speed	km/h	0.9
Engine rated power			Kw/rpm	338/1800
Total crane weight (24m heavy boom, 350t hook block)			t	350
Mean ground pressure			MPa	0.146
Grade-ability (with base boom)				20%
Max. mass of single unit in transport state			t	48
Max. dimension of single unit (turntable) in transport state (L×W×H)			m	11.5×3×3.4

## V. Lifting capacity table in typical working conditions

### 1. Heavy boom standard working condition (HB)

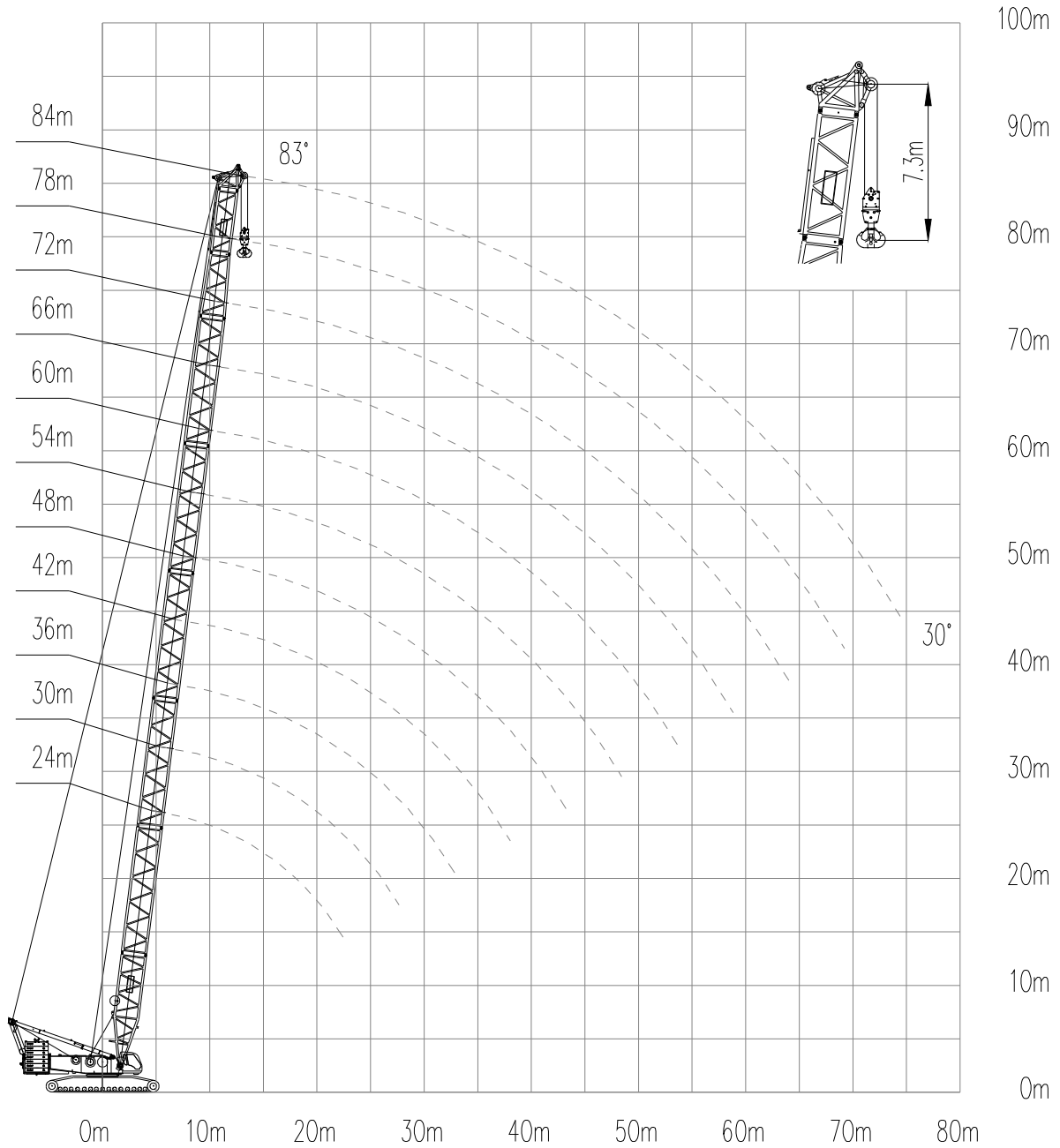



## 150t turntable counterweight +40t car-body counterweight

Radius (m)	Boom length (m)										
	24	30	36	42	48	54	60	66	72	78	84
6	400.0										
7	357.5	356.1									
8	315.7	314.4	313.0								
9	276.2	275.8	273.5	265.2	240.4						
10	244.1	241.3	234.8	228.6	213.7	203.4					
12	182.4	182.5	182.4	178.1	174.1	166.7	159.7	153.5	147.2		
14	155.0	154.5	151.3	148.0	144.7	140.5	135.1	130.2	125.2	120.7	116.2
16	127.3	127.2	126.6	124.0	121.3	120.0	116.4	112.5	108.4	104.7	100.9
18	107.4	107.3	107.0	106.1	104.0	102.8	100.8	98.6	95.1	91.9	88.6
20	92.4	92.3	92.0	91.5	90.6	89.5	87.8	86.3	84.2	81.4	78.6
22	80.7	80.7	80.4	79.8	79.2	78.5	77.3	76.0	74.5	72.8	70.3
24		71.2	71.0	70.4	69.8	69.0	68.3	67.6	66.2	65.0	63.1
26		63.5	63.3	62.7	62.0	61.3	60.6	60.2	59.2	58.1	56.7
28		57.0	56.8	56.3	55.7	54.9	54.1	53.7	52.8	52.3	51.1
30			51.4	50.8	50.2	49.4	48.6	48.2	47.3	46.7	46.0
32			46.6	46.2	45.5	44.7	43.9	43.5	42.6	42.0	41.3
34				42.0	41.5	40.6	39.9	39.4	38.5	37.9	37.1
36				38.4	37.8	37.0	36.3	35.8	35.0	34.4	33.5
38				35.3	34.7	33.9	33.1	32.6	31.8	31.2	30.4
40					31.9	31.1	30.3	29.8	28.9	28.3	27.5
42					29.3	28.5	27.8	27.3	26.5	25.9	25.0
44						26.3	25.5	25.1	24.1	23.5	22.7
46						24.2	23.4	23.0	22.1	21.5	20.7
48						22.2	21.6	21.1	20.2	19.6	18.7
50							19.8	19.4	18.5	17.9	17.1



52							18.2	17.8	16.9	16.3	15.5
54							16.8	16.4	15.5	14.9	14.0
56								15.0	14.1	13.5	12.6
58								13.7	12.8	12.3	11.4
60									11.7	11.1	10.3
62									10.6	10.0	9.1
64									9.6	9.0	8.1
66										8.0	7.2
68										7.2	6.3
70											5.5



## 2. Light boom standard working condition (LB)

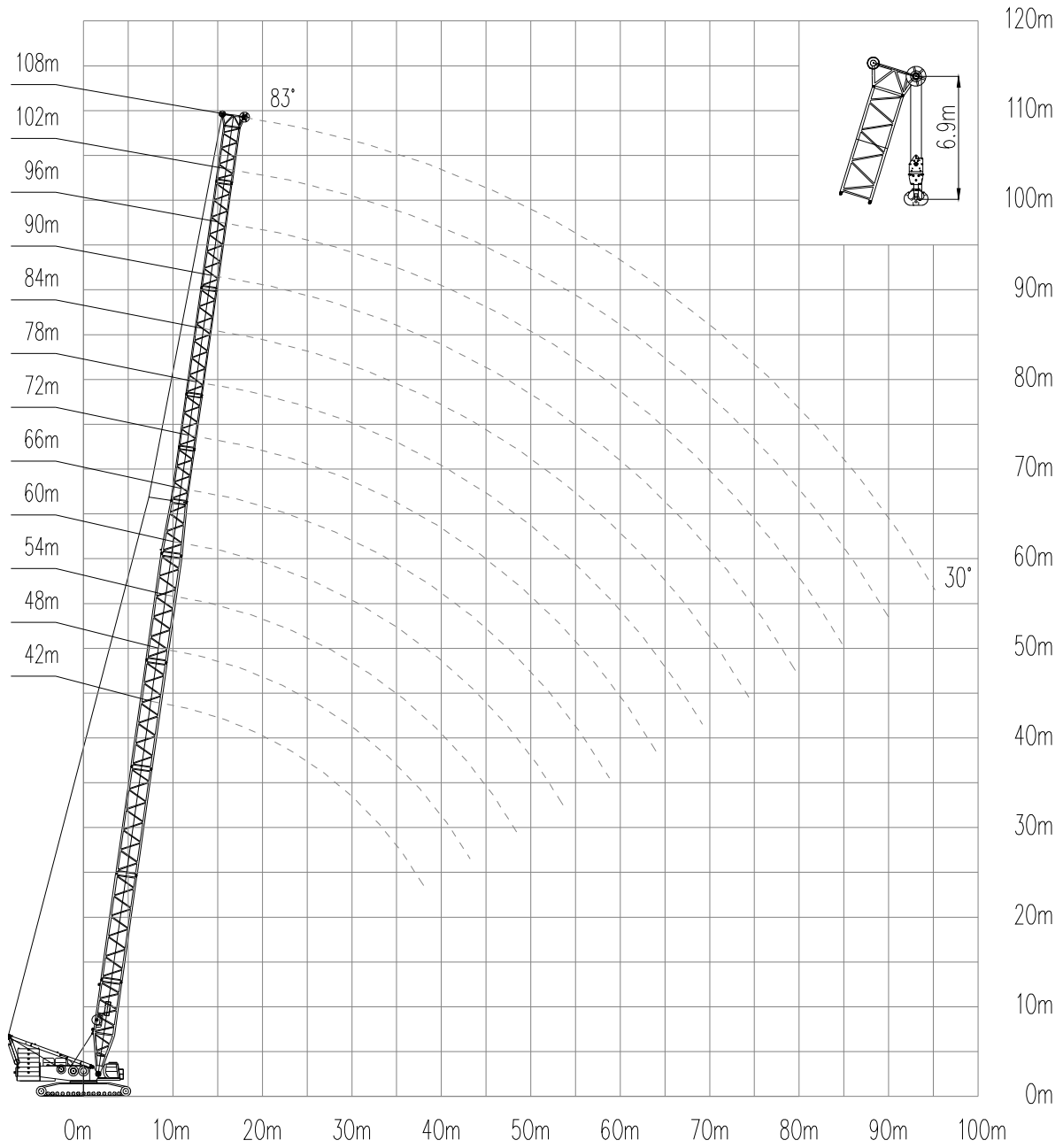



## 150t turntable counterweight +40t car-body counterweight

Radius (m)	Boom length											
	42	48	54	60	66	72	78	84	90	96	102	108
9	220.0	217.6										
10	209.0	208.8	196.3									
12	179.5	172.9	165.8	159.6	153.2	144.4						
14	146.5	143.4	140.5	135.8	130.7	126.6	122.1	110.1	104.7			
16	123.4	120.8	119.4	117.5	113.6	110.3	106.8	103.6	98.0	85.2	76.5	
18	106.3	104.1	103.0	101.4	99.5	97.5	94.4	91.8	88.8	79.6	74.6	61.8
20	92.4	91.2	90.2	88.9	87.2	86.0	84.4	82.2	79.4	77.3	69.8	60.2
22	81.1	80.6	80.0	78.9	77.3	76.3	75.0	73.8	71.6	69.8	67.6	58.7
24	72.1	71.4	70.9	70.7	69.3	68.3	67.1	66.1	64.8	63.4	61.4	57.2
26	64.6	64.0	63.4	63.2	62.4	61.7	60.5	59.7	58.4	57.5	56.0	54.4
28	58.4	57.8	57.2	56.9	56.1	56.1	55.0	54.2	53.0	52.2	51.0	49.8
30	53.2	52.5	51.9	51.7	50.8	50.7	50.2	49.5	48.3	47.6	46.5	45.6
32	48.6	48.0	47.3	47.1	46.3	46.2	45.6	45.3	44.3	43.5	42.5	41.6
34	44.7	44.1	43.4	43.1	42.4	42.2	41.6	41.4	40.6	40.0	39.0	38.2
36	41.2	40.7	40.0	39.7	39.0	38.8	38.2	37.9	37.1	36.9	35.9	35.1
38	38.2	37.5	37.0	36.7	35.8	35.7	35.2	34.9	34.1	33.8	33.2	32.4
40		34.9	34.2	34.0	33.2	33.0	32.4	32.1	31.4	31.1	30.4	29.9
42		32.4	31.7	31.5	30.7	30.6	30.0	29.6	28.9	28.6	27.9	27.5
44			29.5	29.4	28.5	28.4	27.7	27.5	26.7	26.4	25.7	25.3
46			27.6	27.4	26.5	26.4	25.8	25.5	24.7	24.4	23.8	23.2
48			25.7	25.6	24.7	24.6	23.9	23.7	22.9	22.6	21.9	21.4
50				23.8	23.1	22.9	22.3	22.0	21.2	20.9	20.2	19.8
52				22.3	21.6	21.4	20.8	20.5	19.7	19.4	18.7	18.2
54				20.9	20.1	20.0	19.4	19.1	18.2	18.0	17.3	16.8
56					18.8	18.7	18.1	17.9	17.0	16.7	16.0	15.5
58					17.6	17.5	16.9	16.6	15.8	15.5	14.8	14.3
60						16.3	15.8	15.5	14.6	14.3	13.7	13.2



62						15.3	14.7	14.4	13.6	13.3	12.6	12.2
64						14.3	13.8	13.5	12.6	12.4	11.7	11.2
66							12.8	12.5	11.8	11.4	10.7	10.3
68							12.0	11.7	10.9	10.5	9.9	9.4
70								10.9	10.1	9.8	9.1	8.6
74								9.4	8.6	8.3	7.6	7.1
78									7.2	6.9	6.3	5.8

### 3. Tower jib standard working condition (HW)



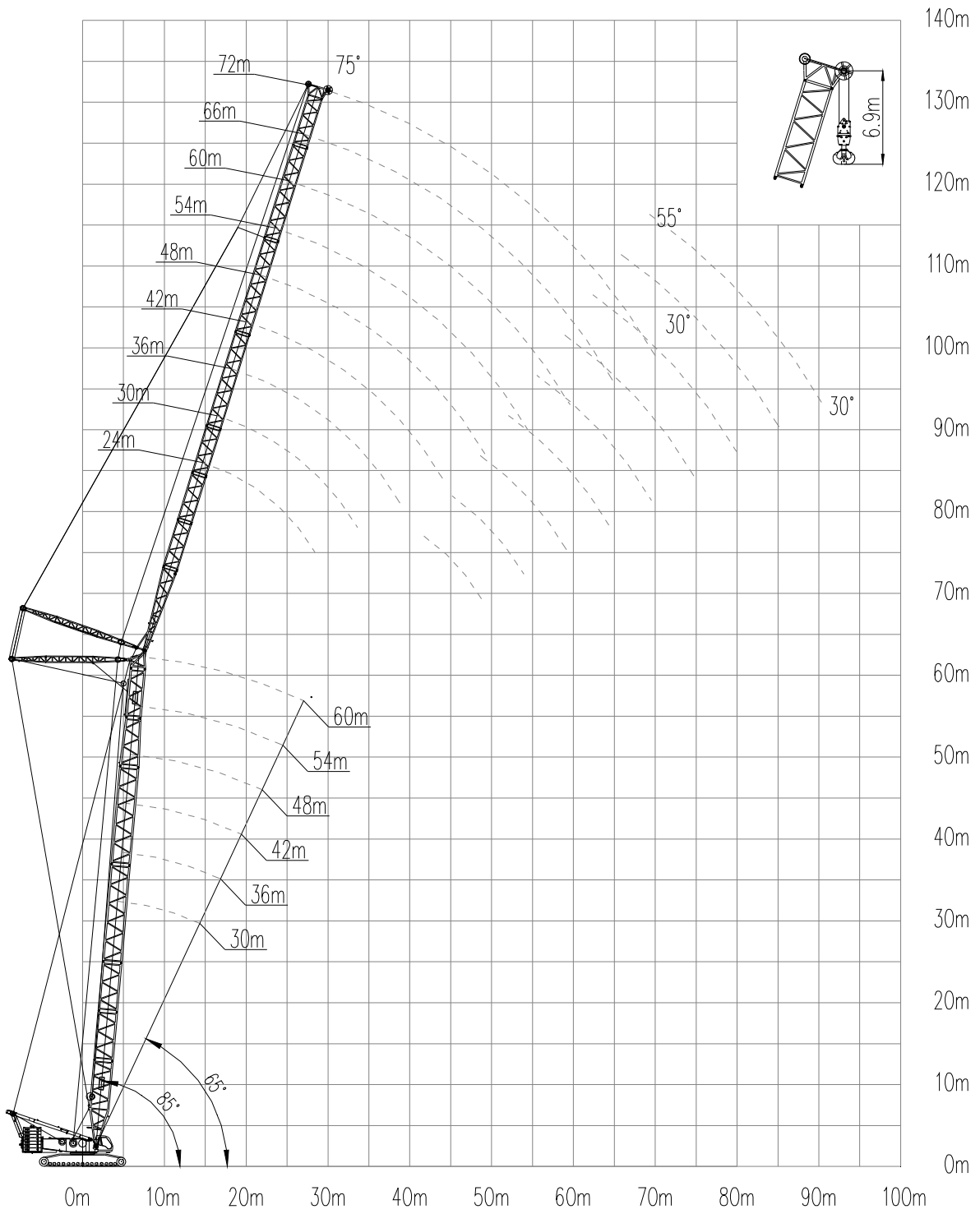



Boom length 30m, boom angle 85°, turntable counterweight 150t+ car-body counterweight 40t

Radius (m)	Tower jib length (m)								
	24	30	36	42	48	54	60	66	72
14	150.0								
16	128.0	123.7	119.8						
18	111.5	109.6	106.5	103.2					
20	98.4	96.8	95.2	92.9	90.1				
22	88.0	86.6	85.3	83.8	81.9	79.6			
24	78.6	78.3	77.1	75.8	74.4	72.9	70.7	62.1	
26	70.7	70.7	70.2	69.0	67.8	66.7	65.0	61.8	52.5
28		64.2	63.9	63.3	62.1	61.1	59.9	58.7	52.2
30		58.7	58.5	58.1	57.2	56.4	55.2	54.3	51.7
32			53.8	53.4	52.8	52.2	51.0	50.3	49.4
34			49.6	49.3	48.8	48.3	47.5	46.7	45.8
36			46.1	45.7	45.2	44.7	44.1	43.5	42.7
38				42.6	42.0	41.6	41.0	40.6	39.9
40				39.7	39.2	38.8	38.2	37.8	37.2
42				37.1	36.7	36.4	35.6	35.3	34.8
44					34.4	34.0	33.4	33.0	32.5
46					32.3	32.1	31.4	31.0	30.5
48						30.2	29.5	29.1	28.6
50						28.4	27.8	27.4	26.9
52						26.8	26.2	25.9	25.3
54							24.7	24.4	23.9
56							23.4	23.1	22.6
58								21.8	21.3
60								20.7	20.2
62								19.6	19.1
64									18.0
66									17.1
68									16.3





Boom length 36m, boom angle 85°, turntable counterweight 150t+ car-body counterweight 40t

Radius (m)	Tower jib length (m)								
	24	30	36	42	48	54	60	66	72
14	140.8								
16	123.2	119.1							
18	109.5	106.0	102.8	99.6					
20	96.9	95.3	92.7	89.9	87.1				
22	86.8	85.4	83.9	81.8	79.2	77.1			
24	78.3	77.2	76.0	74.6	72.7	70.7	68.4		
26	70.5	70.3	69.3	68.1	66.8	65.1	63.1	58.9	50.3
28		63.9	63.5	62.4	61.3	60.3	58.5	57.0	49.9
30		58.5	58.3	57.6	56.5	55.6	54.3	52.9	49.6
32		53.7	53.6	53.1	52.4	51.5	50.4	49.4	47.9
34			49.4	49.1	48.5	47.9	46.8	46.1	44.8
36			45.9	45.5	44.9	44.6	43.7	43.0	42.0
38				42.4	41.8	41.5	40.7	40.1	39.3
40				39.6	39.0	38.6	38.0	37.6	36.8
42				36.9	36.5	36.1	35.4	35.1	34.5
44					34.2	33.8	33.2	32.8	32.2
46					32.1	31.9	31.2	30.8	30.3
48						30.0	29.3	29.0	28.4
50						28.3	27.6	27.3	26.7
52						26.7	26.0	25.7	25.1
54							24.6	24.3	23.7
56							23.2	22.9	22.4
58							22.0	21.7	21.2
60								20.6	20.0
62								19.5	19.0
64									18.0
66									17.0
68									16.1





Boom length 42m, boom angle 85°, turntable counterweight 150t+ car-body counterweight 40t

Radius (m)	Tower jib length (m)								
	24	30	36	42	48	54	60	66	72
14	135.1								
16	118.6	114.7							
18	105.7	102.3	99.3						
20	95.2	92.3	89.6	86.9	84.2				
22	85.4	83.9	81.6	79.1	76.7	74.6			
24	77.3	76.0	74.8	72.6	70.4	68.4	65.7		
26	70.3	69.4	68.2	66.9	65.0	63.2	61.1	55.8	
28		63.7	62.7	61.6	60.2	58.6	56.7	55.2	47.6
30		58.2	57.9	56.9	55.7	54.5	52.7	51.3	47.4
32		53.5	53.3	52.7	51.7	50.8	49.2	47.9	46.4
34			49.3	48.8	48.1	47.3	46.1	44.8	43.4
36			45.7	45.3	44.7	44.1	43.1	42.1	40.8
38				42.1	41.6	41.2	40.3	39.6	38.4
40				39.4	38.8	38.4	37.7	37.1	36.1
42				36.8	36.3	35.9	35.3	34.9	34.1
44					34.0	33.7	33.0	32.6	32.1
46					32.0	31.7	30.9	30.6	30.0
48					30.1	29.8	29.1	28.8	28.2
50						28.1	27.4	27.1	26.5
52						26.5	25.9	25.5	24.9
54							24.4	24.1	23.5
56							23.1	22.7	22.2
58							21.8	21.5	21.0
60								20.4	19.8
62								19.4	18.8
64									17.8
66									16.8
68									16.0





Boom length 48m, boom angle 85°, turntable counterweight 150t+ car-body counterweight 40t

Radius (m)	Tower jib length (m)								
	24	30	36	42	48	54	60	66	72
16	114.1	110.4							
18	101.9	98.6	95.7						
20	91.9	89.1	86.5	83.8					
22	83.7	81.2	78.9	76.5	74.2				
24	76.1	74.4	72.4	70.2	68.1	66.2	61.7		
26	69.5	68.3	66.8	64.9	62.9	61.1	59.1	52.7	
28		62.8	61.8	60.2	58.3	56.7	54.8	52.5	45.2
30		57.9	57.1	56.0	54.3	52.8	51.0	49.6	45.0
32		53.2	53.0	52.0	50.8	49.4	47.7	46.4	44.7
34			49.0	48.4	47.4	46.2	44.7	43.4	42.0
36			45.4	45.0	44.3	43.5	41.9	40.8	39.5
38			42.3	41.9	41.4	40.7	39.5	38.4	37.1
40				39.1	38.5	38.2	37.2	36.2	35.0
42				36.6	36.1	35.7	35.0	34.2	33.0
44					33.8	33.5	32.7	32.3	31.2
46					31.8	31.4	30.7	30.4	29.5
48					29.9	29.6	28.9	28.5	27.9
50						27.9	27.2	26.9	26.2
52						26.3	25.7	25.3	24.7
54							24.3	23.9	23.3
56							22.9	22.6	22.0
58							21.7	21.3	20.8
60								20.2	19.6
62								19.2	18.6
64								18.1	17.6
66									16.7
68									15.8





Boom length 54m, boom angle 85°, turntable counterweight 150t+ car-body counterweight 40t

Radius (m)	Tower jib length (m)								
	24	30	36	42	48	54	60	66	72
16	109.6								
18	98.1	94.9	92.1						
20	88.7	85.9	83.5	80.8					
22	80.8	78.4	76.1	73.9	71.5				
24	74.3	72.0	70.0	67.9	65.8	63.9			
26	68.4	66.6	64.7	62.7	60.8	59.1	57.1	49.6	
28	62.9	61.8	60.1	58.3	56.4	54.8	52.9	49.4	42.8
30		57.2	56.0	54.3	52.5	51.1	49.4	48.0	42.6
32		52.9	52.3	50.9	49.2	47.8	46.1	44.8	42.3
34			48.7	47.7	46.2	44.8	43.1	42.0	40.6
36			45.1	44.7	43.4	42.1	40.6	39.5	38.1
38			42.0	41.6	40.9	39.8	38.2	37.1	35.8
40				38.8	38.3	37.5	36.1	35.1	33.7
42				36.4	35.8	35.4	34.1	33.1	31.9
44				34.1	33.6	33.2	32.2	31.3	30.2
46					31.6	31.2	30.5	29.7	28.6
48					29.7	29.3	28.7	28.2	27.1
50						27.6	27.0	26.6	25.7
52						26.1	25.5	25.1	24.4
54						24.6	24.1	23.7	23.1
56							22.7	22.4	21.8
58							21.5	21.2	20.6
60								20.0	19.5
62								19.0	18.4
64								18.0	17.4
66									16.5
68									15.6
70									14.9





Boom length 60m, boom angle 85°, turntable counterweight 150t+ car-body counterweight 40t

Radius (m)	Tower jib length (m)								
	24	30	36	42	48	54	60	66	72
16	105.2								
18	94.4	91.4							
20	85.4	82.8	80.4	77.8					
22	78.0	75.7	73.4	71.2	68.9				
24	71.7	69.6	67.6	65.5	63.5	61.2			
26	66.3	64.3	62.5	60.5	58.7	57.0	53.3		
28	61.7	59.8	58.1	56.3	54.5	52.9	51.0	46.2	40.3
30		55.7	54.2	52.5	50.8	49.4	47.6	45.2	40.0
32		52.3	50.8	49.2	47.6	46.2	44.5	43.2	39.4
34		48.5	47.7	46.2	44.7	43.3	41.6	40.5	38.0
36			44.8	43.4	42.0	40.7	39.2	38.1	36.7
38			41.7	41.0	39.6	38.4	36.8	35.8	34.5
40				38.5	37.4	36.3	34.8	33.7	32.5
42				36.1	35.4	34.3	32.9	32.0	30.7
44				33.8	33.3	32.5	31.2	30.2	29.0
46					31.3	30.9	29.5	28.7	27.4
48					29.4	29.0	28.1	27.2	26.0
50						27.4	26.7	25.9	24.7
52						25.9	25.2	24.5	23.5
54						24.4	23.8	23.4	22.3
56							22.5	22.1	21.2
58							21.2	20.9	20.2
60							20.1	19.8	19.2
62								18.7	18.1
64								17.8	17.2
66									16.3
68									15.4
70									14.6





#### 4. Goose head jib standard working condition (HJ)

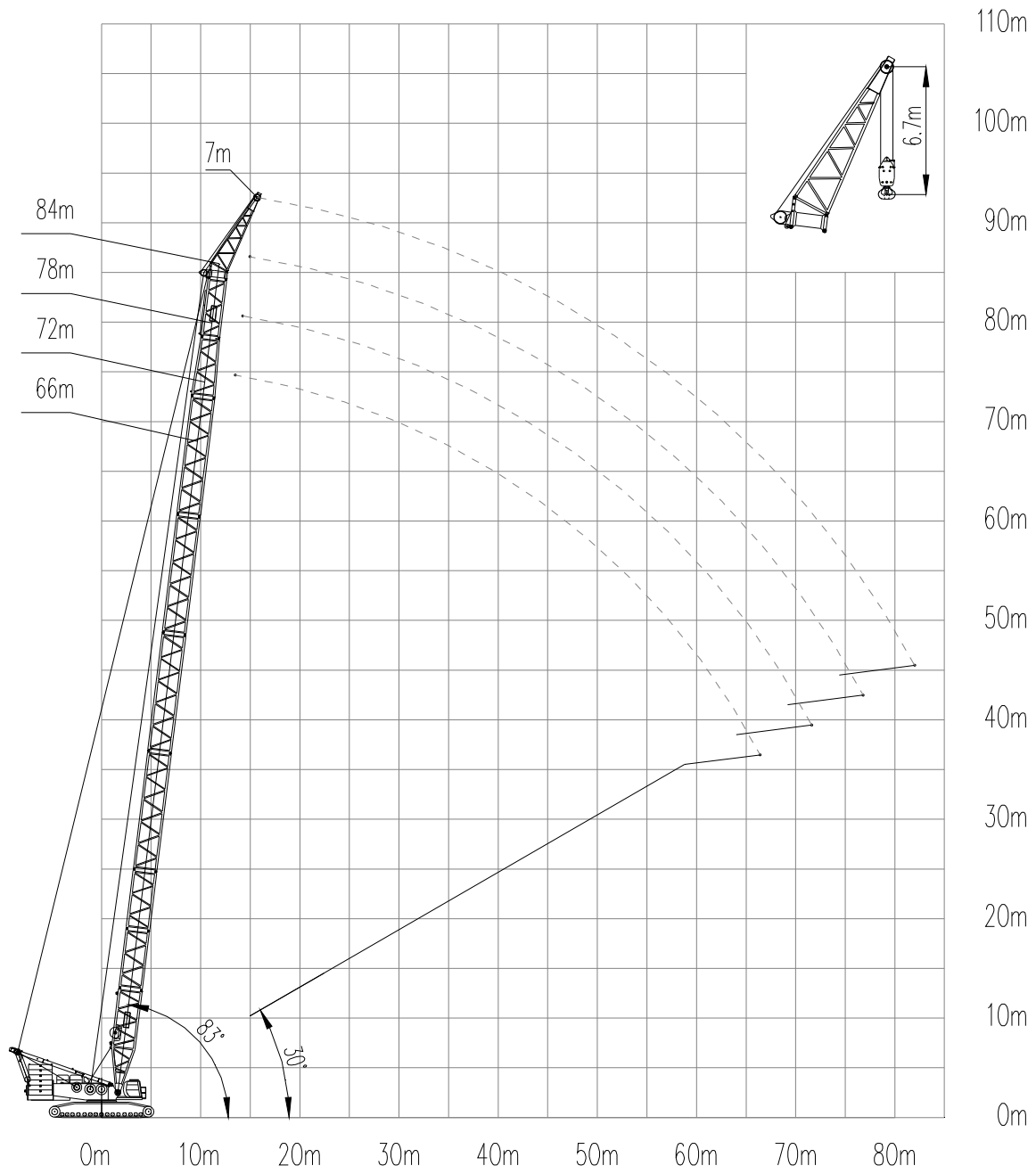



Turntable counterweight 150t+car-body counterweight 40t

	Boom length			
Radius (m)	66	72	78	84
14	119.7			
15	119.7	115.7	115.3	
16	115.5	111.6	108.0	101.2
18	98.8	98.5	95.4	92.2
20	87.9	85.2	85.2	82.3
22	77.9	76.4	74.3	71.8
24	69.6	68.3	67.0	65.0
26	62.8	61.5	60.3	59.1
28	56.7	55.7	54.6	53.4
30	51.3	50.5	49.7	48.5
32	46.6	45.8	45.2	44.2
34	42.5	41.6	41.1	40.3
36	38.9	38.0	37.4	36.7
38	35.7	34.9	34.3	33.5
40	32.9	32.0	31.4	30.6
42	30.4	29.5	28.9	28.0
44	28.1	27.3	26.7	25.8
46	26.0	25.1	24.5	23.7
48	24.2	23.3	22.7	21.8
50	22.4	21.5	21.0	20.1
52	20.9	20.0	19.4	18.4
54	19.4	18.5	17.9	17.0
56	18.0	17.2	16.6	15.6
58	16.8	15.9	15.3	14.4
60	15.6	14.7	14.2	13.2
62	14.6	13.7	13.1	12.1
64	13.5	12.6	12.0	11.2



66	12.5	11.6	11.1	10.2
68		10.8	10.2	9.3
70		9.9	9.3	8.4
74			7.8	6.9
78				5.4

## 5. Fixed jib standard working condition (HF)

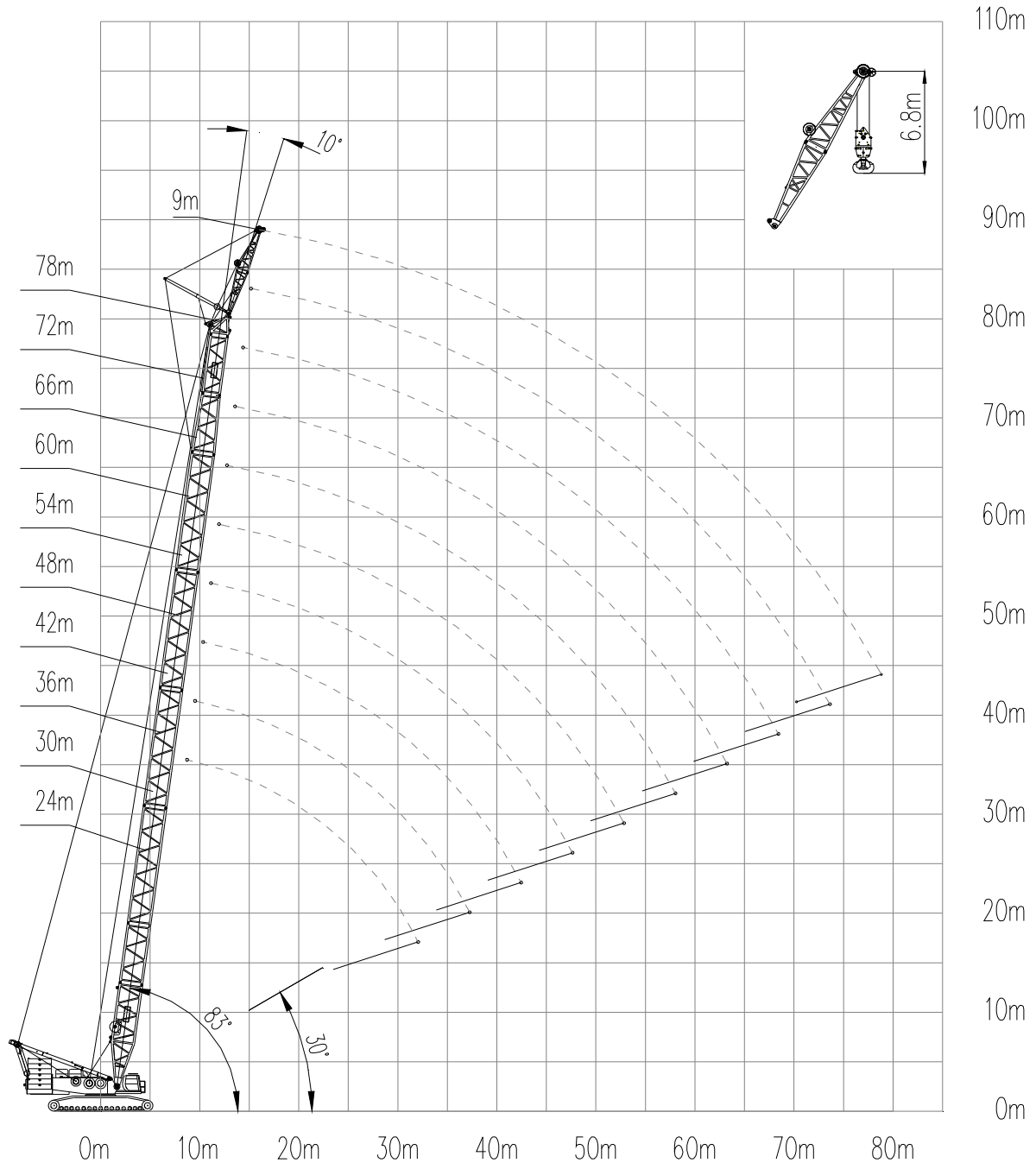





Fixed jib length 9m, jib offset angle 10°, turntable counterweight 150t+car-body counterweight 40t

Radius (m)	Boom length (m)									
	24	30	36	42	48	54	60	66	72	78
9	200.0									
10	200.0	190.0	190.0							
12	185.5	181.2	174.2	166.8	159.8					
14	150.4	147.2	143.9	140.4	135.0	129.8	124.8	117.2		
16	125.4	123.3	120.7	119.1	116.3	112.0	107.9	104.3	100.5	97.0
18	105.9	105.4	103.6	102.1	100.2	98.1	94.6	91.5	88.2	85.2
20	91.2	90.6	90.1	89.0	87.3	85.6	83.8	81.0	78.2	75.5
22	79.7	79.1	78.6	77.8	77.0	75.4	73.9	72.4	69.8	67.5
24	70.5	69.9	69.3	68.6	67.8	67.1	65.6	64.5	62.7	60.6
26	63.0	62.3	61.8	61.0	60.2	59.5	58.7	57.7	56.3	54.7
28	56.6	56.1	55.4	54.6	53.9	53.1	52.3	51.8	50.6	49.6
30	51.2	50.6	50.1	49.3	48.5	47.7	46.8	46.4	45.5	44.7
32	46.6	46.1	45.4	44.7	43.9	43.0	42.2	41.6	40.9	40.2
34		42.0	41.4	40.7	39.9	39.0	38.2	37.6	36.8	36.1
36		38.5	37.9	37.1	36.4	35.5	34.7	34.1	33.2	32.6
38			34.8	34.0	33.3	32.4	31.5	31.0	30.0	29.5
40			32.0	31.3	30.5	29.6	28.7	28.1	27.3	26.6
42			29.5	28.8	28.0	27.1	26.2	25.7	24.8	24.1
44				26.5	25.7	24.9	23.9	23.4	22.5	21.9
46				24.4	23.7	22.8	21.9	21.4	20.4	19.9
48					21.9	21.0	20.0	19.5	18.6	18.0
50					20.1	19.3	18.3	17.8	16.9	16.2
52					18.5	17.7	16.8	16.2	15.3	14.7
54						16.2	15.4	14.8	13.9	13.2
56						14.9	14.1	13.5	12.5	11.9
58						13.7	12.8	12.3	11.3	10.6
60							11.6	11.1	10.2	9.5
62							10.5	10.0	9.1	8.5



64								9.0	8.1	7.4
66								8.0	7.1	6.5
68								7.1	6.3	5.6
70									5.4	

### 6. TBM jib standard working condition (HFS)

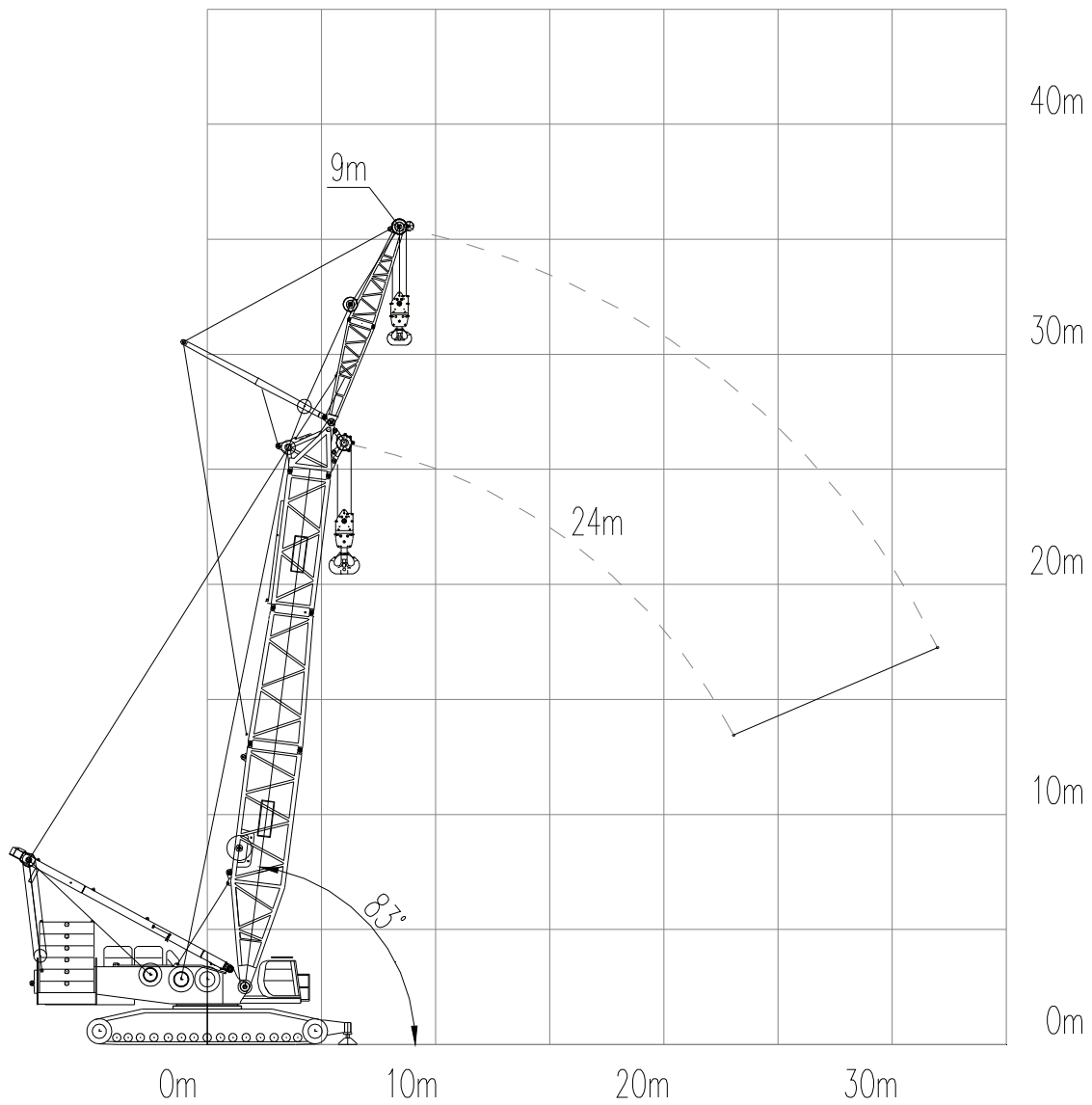





Turntable counterweight      150t                      Car-body counterweight      40t

Boom length                      24m                      Jib length                      9m

Jib angle                          10°

Boom angle	Main hook radius	Main hook load	Aux. hook radius	Aux. hook load	Total load of main and aux. hooks
°	(m)	(t)	(m)	(t)	(t)
82.8	6	350.0	8.4	185	350.0
80.4	7	350.0	9.8	185	302.5
77.9	8	309.4	11.2	185	260.3
75.4	9	270.7	12.6	177.8	228.0
72.9	10	239.2	14.0	150.2	195.8
70.3	11	209.0	15.4	129.5	168.5
67.7	12	178.7	16.8	113.1	147.4
65.0	13	159.5	18.2	100.1	130.7
62.3	14	141.1	19.6	89.3	117.1
59.5	15	125.9	20.9	80.3	105.8
56.6	16	113.3	22.3	72.5	96.2
53.5	17	102.5	23.7	66.0	88.1
50.4	18	93.3	25.1	60.2	81.0
47.0	19	85.3	26.5	55.2	74.8
43.5	20	78.3	27.8	50.7	69.4
35.4	22	66.4	30.6	43.1	60.2



### 7. Heavy boom superlift working condition (SHB)

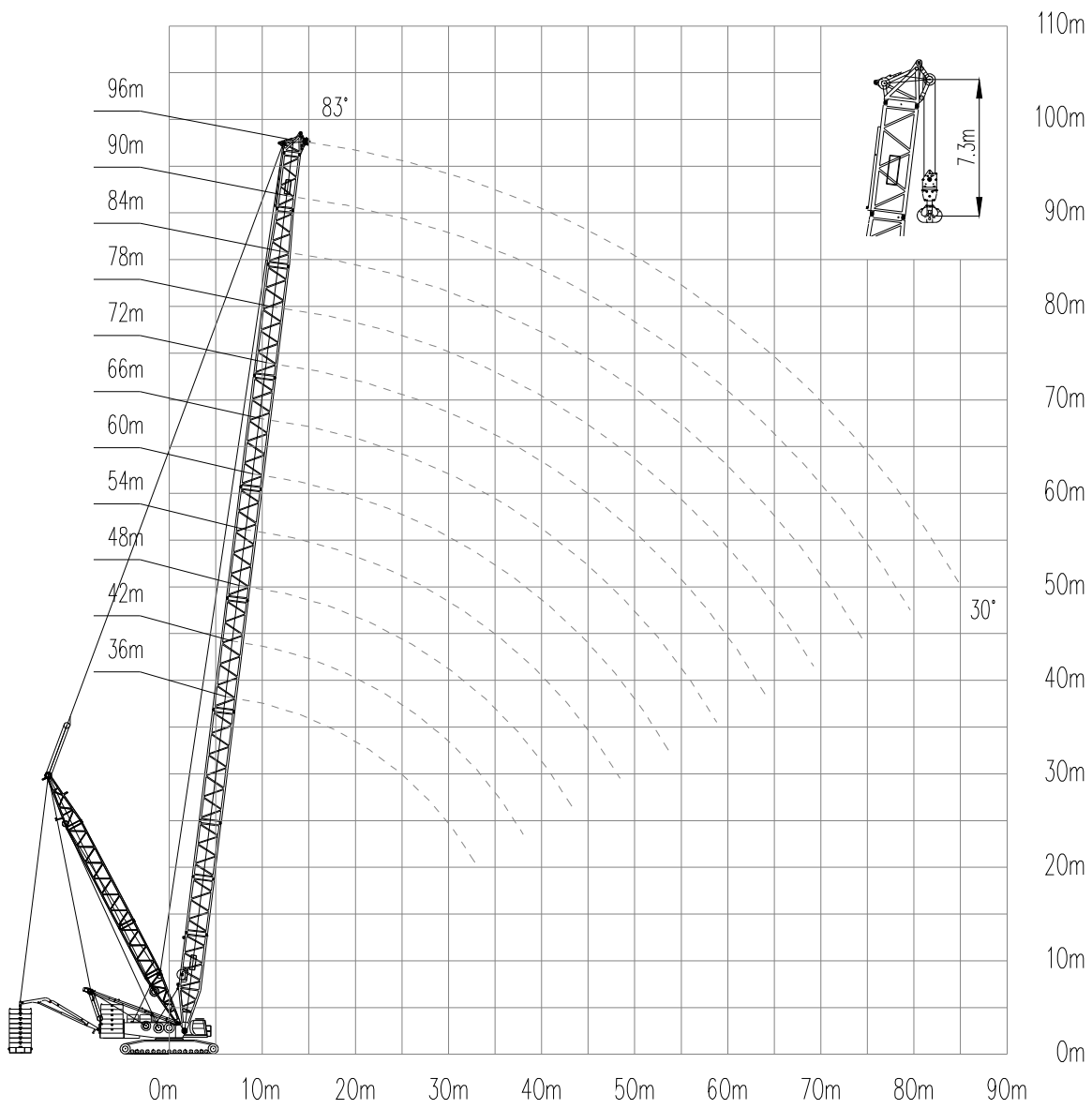



Turntable counterweight	110t	Car-body counterweight	40t
Superlift mast radius	13m	Superlift counterweight radius	16m
Superlift counterweight	230t		

Radius (m)	Boom length (m)										
	36	42	48	54	60	66	72	78	84	(90)	(96)
8	400*										
9	400*	400*	400*								
10	400*	400*	392*	352*							
12	384*	392*	384*	352*	326*	281*	242*				
14	367	372	372	338*	327*	282*	244*	203*	174.4*	150.9*	
16	317	322	321	324	314	282*	245*	203*	174.8*	151.2*	131.5*
18	279	286	286	285	284	272	245*	204*	175.2*	151.5*	131.7*
20	256	255	254	254	253	253	246	204*	175.5*	151.7*	131.8*
22	228	230	229	229	228	227	236	204	175.7*	151.8*	131.9*
24	204	208	208	208	207	206	214	204	175.8	151.9*	131.9*
26	184.5	195.9	191	190.3	189.5	196.9	196	195.5	174.8	151.3*	131.6*
28	167.1	178	176	182.5	181.6	181.2	180.3	179.7	173.7	150.3	130.8*
30	151.9	162.5	169.6	168.9	168	167.6	166.7	166.2	165.2	149.3	129.9*
32	138.2	148.8	157.1	157.1	156.2	155.8	154.9	154.3	153.3	148.2	128.9
34		136.6	144.6	146.6	145.7	145.3	144.4	143.9	142.9	142	128
36		125.5	133.5	137.3	136.5	136	135.2	134.6	133.6	132.8	127
38		115.3	123.5	129	128.2	127.8	126.9	126.3	125.4	124.5	123.5
40			114.4	119.9	120.6	120.3	119.4	118.9	117.9	117.1	116.1
42			105.9	111.6	113.3	113	112.2	111.8	110.9	110.1	109.3
44				104	106.7	106.4	105.6	105.2	104.3	103.5	102.7
46				96.9	100.7	100.4	99.7	99.2	98.4	97.6	96.7
48				90.3	95.1	95	94.2	93.7	92.9	92.1	91.2
50					89.1	90	89.2	88.8	87.9	87.2	86.3
54					78	81.2	80.5	80	79.2	78.4	77.5
58						72.5	73	72.5	71.7	70.9	70
62							66.5	66.1	65.2	64.5	63.6
66								60.4	59.6	58.8	57.9



70									54.6	53.8	53
74									50.2	49.4	48.5
78										45.5	44.6
82											41

### 8. Light boom superlift working condition (SLB)

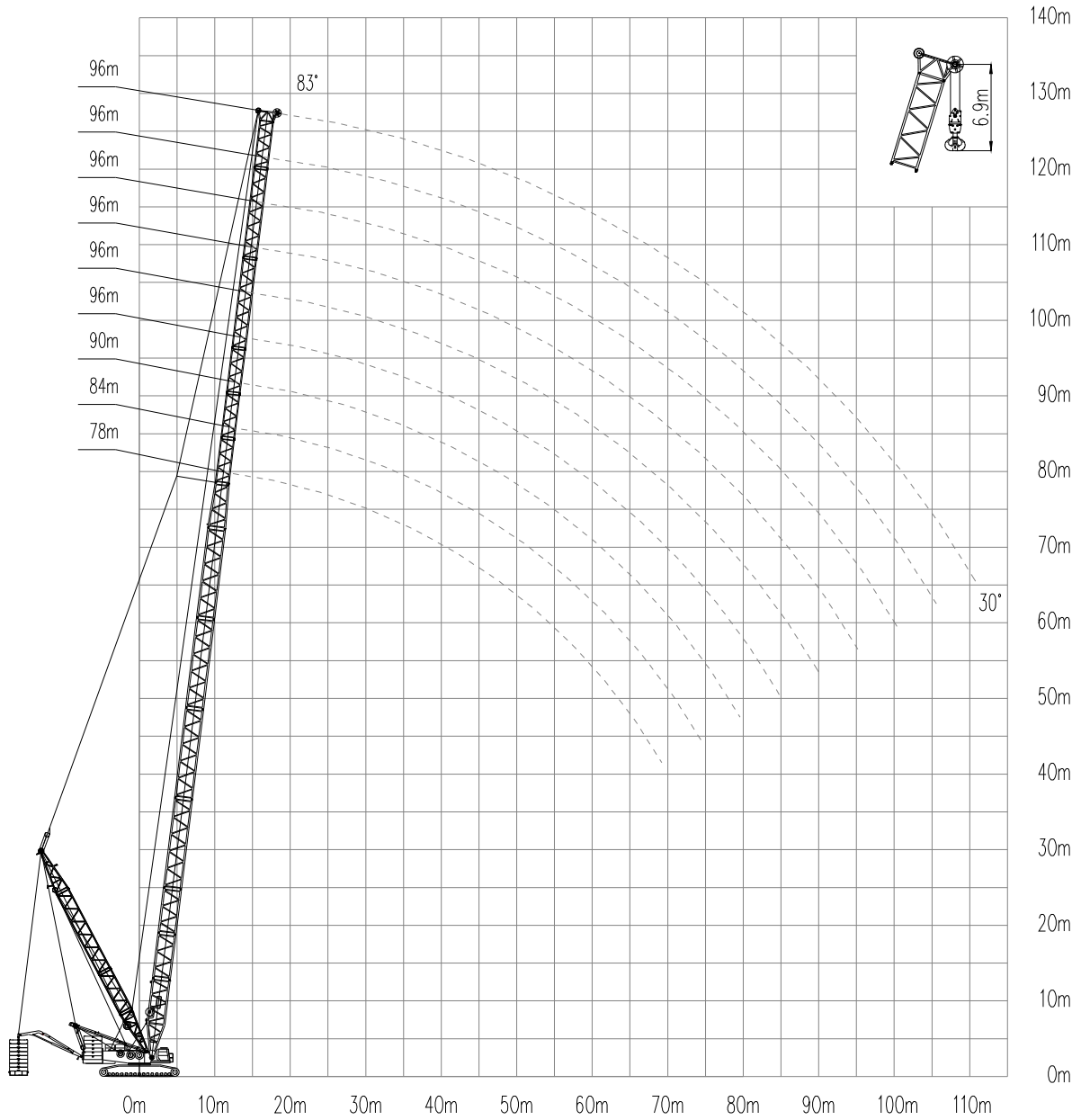



Turntable counterweight 110t Car-body counterweight 40t

Superlift mast radius 13m Superlift counterweight radius 16m

Superlift counterweight 230t

Radius (m)	Boom length (m)									
	72	78	84	90	96	102	108	114	120	126
12	216*									
14	218*	193.3*	168.9*	142.4*						
16	219*	192.8*	168.7*	142.2*	125.6*	107.1*				
18	220*	192.1*	168.3*	138.8*	125.3*	106.7*	91.4*	78.1*	67.3*	
20	220*	191.2*	167.8*	135.4*	124.9*	106.3*	90.9*	77.6*	66.8*	57.8*
22	220	190.2*	167.2*	132.3*	124.4*	105.8*	90.4*	77.1*	66.3*	57.3*
24	214	189	166.4*	129.3*	123.8*	105.2*	89.9*	76.6*	65.8*	56.8*
26	196.3	187.7	165.6	125.7*	123.2*	104.7*	88.6*	76*	65.2*	55.2*
28	184.6	183.8	164.7	123.1*	122.6*	104.1*	86.4*	74.9*	62.9*	53.7*
30	171	170.2	163.8	120*	121.9*	103.4*	84.2*	73.1*	61.2*	52.2*
32	159.2	158.3	157.2	116.2*	120.8*	102.8*	82.2*	71.3*	60.3*	50.7*
34	148.7	147.9	146.8	112.5*	118.6	101.7*	80.1*	69.5*	58*	49.3*
36	139.5	138.7	137.5	109.1	115.8	99.9*	78.1*	68.8*	56.3*	48*
38	131.2	130.4	129.3	105.8	113.6	97.9*	76.1*	66*	54.9*	46.7*
40	123.7	122.9	121.8	102.8	111.5	95.6	74.1*	64.4*	53.4*	45.4*
42	116.5	115.8	114.8	100	109.5	94.1	72.4*	62.8*	52*	44.2*
44	109.9	109.2	108.2	97.4	107	92.2	70.7*	61.2*	50.7*	43*
46	103.9	103.2	102.2	95	101	90.4	68.9*	59.8*	49.4*	41.9*
48	98.5	97.8	96.8	92.8	95.6	88.7	67.4*	58.4*	48.2*	40.8*
50	93.5	92.8	91.8	90.7	90.6	87	65.8*	56.9*	47*	39.8*
54	84.8	84.1	83.1	82.7	81.9	81.8	63.1	54.5*	44.8*	37.9*
58	77.3	76.6	75.6	75.3	74.4	74.3	60.4	52.2*	42.8*	36.2*
62	70.8	70.1	69.1	68.8	68	67.9	57.8	50.1	41*	34.3*
66		64.5	63.5	63.2	62.3	62.2	55.6	48.4	39.3*	32.7*
70			58.5	58.2	57.4	57.3	53.7	46.6	37.6*	31.2*
74			54.1	53.8	53	52.9	52.1	45.1	36.1*	29.8*
78				49.9	49	48.9	48.5	43.7	34.9	28.7*





82					45.5	45.4	45	42.6	33.8	27.6*
86						42.2	41.8	41.7	32.8	26.7*
90						39.3	38.9	38.8	32.1	25.9
94							36	36.2	31.5	25.3
98								33.8	31	24.7
102									30.8	24.3
106									28.8	24.1
110										24

**9. Tower jib superlift working condition (SHW)**

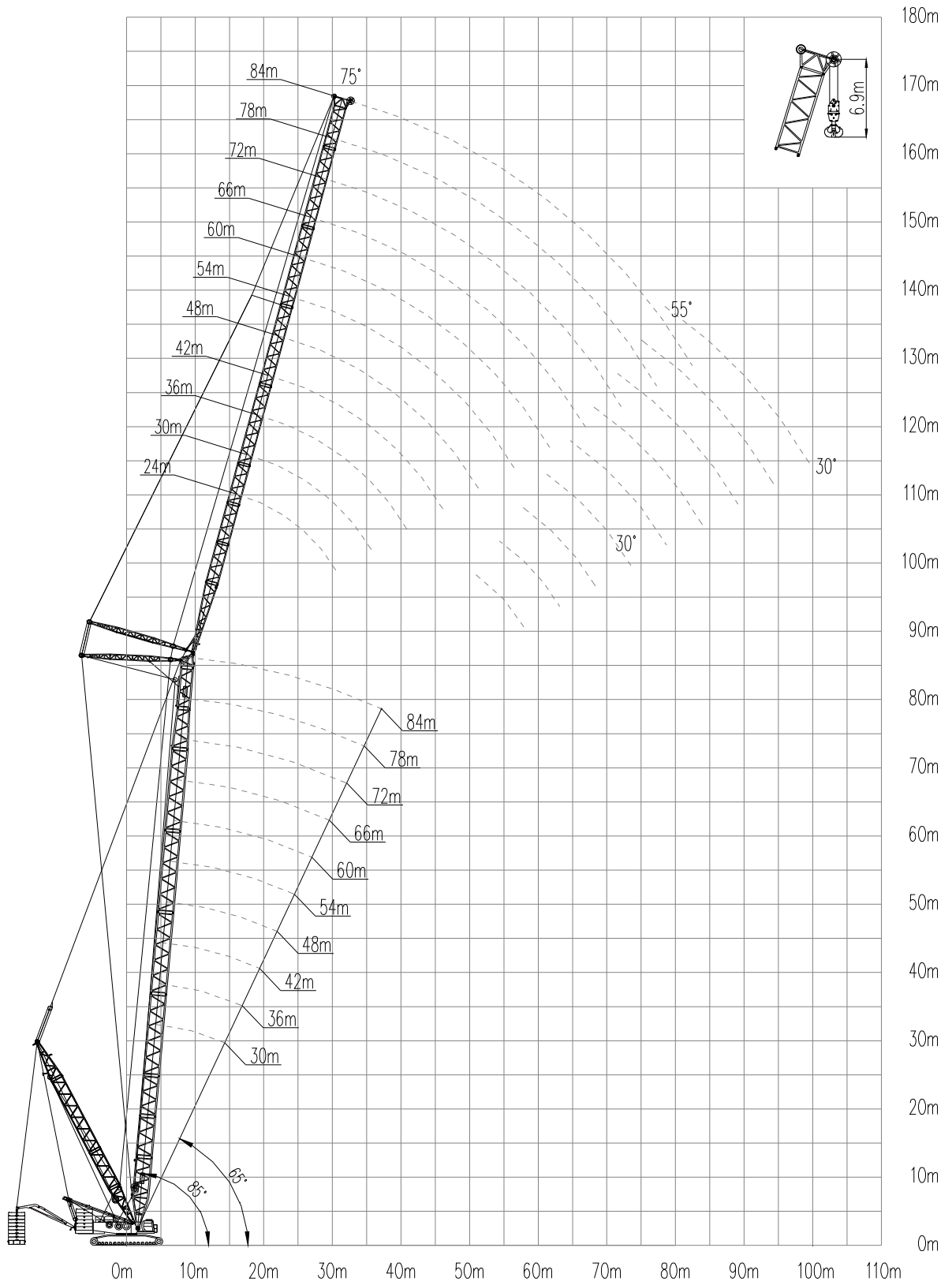



Boom length 36m

Boom angle 85°

Turntable counterweight 110t

Car-body counterweight 40t

Superlift mast radius 13m

Superlift counterweight radius 16m

superlift counterweight 230t

Radius (m)	Tower jib length (m)										
	24	30	36	42	48	54	60	66	72	78	84
14	220										
16	220	187									
18	211.4	186.1	154.8	127.7							
20	182	173.2	151.2	127.3	104.4						
22	159.7	159.8	142.7	124.6	104	86.1					
24	142.2	143.1	133.6	118.7	103.5	85.7	73.3				
26	128	128.8	124.3	112.5	99.7	85.2	73	61.8	52.7		
28		117	115	106	95.3	84.2	72.7	61.5	52.4	44.9	
30		107.2	106.1	99.3	90.7	81.1	72.3	61.2	52	44.6	38.8
32		98.8	97.5	92.8	85.9	77.8	70.1	60.8	51.7	44.3	38.5
34			89.5	86.4	81.1	74.3	67.7	60.3	51.3	44	38.2
36			82	80.3	76.4	70.8	65.1	58.5	50.9	43.6	37.9
38				74.5	71.7	67.3	62.4	56.6	50.6	43.3	37.5
40				69	67.2	63.8	59.7	54.6	49.2	42.9	37.2
42				63.8	62.9	60.3	57	52.6	47.7	42.5	36.9
44					58.7	56.9	54.3	50.6	46.2	41.6	36.6
46					54.8	53.6	51.7	48.5	44.6	40.5	36.3
48						50.5	49	46.4	43	39.3	35.5
50						47.5	46.5	44.4	41.4	38	34.6
54							41.6	40.4	38.2	35.6	32.7
58							37.2	36.6	35.1	33.1	30.7
62								33	32.1	30.6	28.7
66									29.2	28.2	26.8
70										26	24.9
74											23
78											21.3



Boom length 42m

Boom angle 85°

Turntable counterweight 110t

Car-body counterweight 40t

Superlift mast radius 13m

Superlift counterweight radius 16m

superlift counterweight 230t

Radius (m)	Tower jib length (m)										
	24	30	36	42	48	54	60	66	72	78	84
14	210.8										
16	208.5	175.8									
18	191.1	168.8	145.6								
20	173.3	157.1	138.4	118.5	97.8						
22	156	144.8	130.4	115	97.7	81.3					
24	139.9	132.6	121.8	109.3	96.4	81.1	69.5				
26	125.1	120.8	113.1	103.3	92.4	80.7	69.3	58.9			
28		109.7	104.5	97	88.1	78.6	69.1	58.7	50.1	43.1	
30		99.4	96.3	90.7	83.5	75.4	67.8	58.5	49.9	42.9	37.3
32		90	88.4	84.5	78.9	72.1	65.5	58.2	49.6	42.6	37.1
34			81	78.5	74.2	68.7	63	56.6	49.3	42.3	36.8
36			74.2	72.8	69.7	65.2	60.3	54.7	49	42.1	36.6
38			67.8	67.4	65.2	61.7	57.7	52.8	47.6	41.8	36.3
40				62.3	60.9	58.2	55	50.8	46.1	41.4	36
42				57.5	56.9	54.9	52.3	48.7	44.5	40.3	35.7
44					53	51.7	49.6	46.6	42.9	39.1	35.3
46					49.4	48.5	47	44.5	41.3	37.8	34.3
48					45.9	45.6	44.5	42.4	39.7	36.6	33.4
50						42.7	42	40.4	38.1	35.3	32.4
54							37.4	36.5	34.8	32.8	30.4



58							33.2	32.8	31.7	30.2	28.3
62								29.4	28.8	27.8	26.3
66									26.1	25.4	24.3
70										23.2	22.4
74										21.1	20.6
78											18.9

Boom length 48m

Boom angle 85°

Turntable counterweight 110t

Car-body counterweight 40t

Superlift mast radius 13m

Superlift counterweight radius 16m

superlift counterweight 230t

Radius (m)	Tower jib length (m)										
	24	30	36	42	48	54	60	66	72	78	84
16	188.2	163									
18	173.4	153.8	133.7								
20	157.9	143.4	127.2	106.5							
22	142.8	132.5	119.9	106.4	91.5						
24	128.6	121.6	112	101.1	89.8	76.5	65.8				
26	115.4	111	104.1	95.5	86	76.3	65.7	56.1			
28	103.6	101	96.2	89.6	81.8	73.5	65.5	55.9	47.9		
30		91.7	88.6	83.8	77.5	70.4	63.6	55.7	47.8	41.2	35.9
32		83.2	81.5	78	73.1	67.2	61.3	55	47.5	41	35.7
34			74.7	72.4	68.7	63.9	58.8	53.3	47.3	40.7	35.5
36			68.5	67.1	64.4	60.5	56.3	51.4	46.3	40.5	35.3
38			62.7	62.1	60.2	57.2	53.7	49.4	44.8	40.2	35
40				57.4	56.2	53.9	51	47.4	43.3	39.2	34.8
42				53.1	52.4	50.7	48.4	45.4	41.8	38	34.3
44					48.8	47.6	45.9	43.3	40.2	36.8	33.4



46					45.4	44.7	43.4	41.3	38.6	35.5	32.4
48					42.2	41.9	41	39.3	36.9	34.3	31.4
50						39.3	38.6	37.3	35.3	33	30.4
54						34.4	34.3	33.6	32.2	30.4	28.4
58							30.3	30.1	29.2	27.9	26.3
62								26.9	26.4	25.5	24.3
66									23.8	23.3	22.4
70										21.1	20.5
74										19.1	18.7
78											17.1

Boom length 54m

Boom angle 85°

Turntable counterweight 110t

Car-body counterweight 40t

Superlift mast radius 13m

Superlift counterweight radius 16m

superlift counterweight 230t

Radius (m)	Tower jib length (m)										
	24	30	36	42	48	54	60	66	72	78	84
16	168.8										
18	156	139.2	121.9								
20	142.6	130	116	101.7							
22	129.4	120.2	109.3	97.8	85.3						
24	116.9	110.5	102.2	92.8	83	72					
26	105.3	101	94.9	87.5	79.3	70.9	62.1	53.2			
28	94.8	92.1	87.8	82.1	75.3	68.2	61.3	53.1	45.7		
30		83.7	80.9	76.6	71.2	65.2	59.2	53	45.6	39.4	
32		76.1	74.3	71.3	67.1	62	56.9	51.4	45.4	39.3	34.3



34			68.2	66.1	62.9	58.8	54.5	49.6	44.7	39.1	34.1
36			62.5	61.3	58.9	55.6	52	47.8	43.3	38.9	33.9
38			57.3	56.7	55	52.4	49.4	45.8	41.8	37.8	33.7
40				52.4	51.3	49.3	46.9	43.8	40.3	36.7	33.1
42				48.4	47.7	46.3	44.4	41.8	38.8	35.5	32.2
44				44.7	44.4	43.4	42	39.8	37.2	34.3	31.3
46					41.3	40.7	39.6	37.9	35.6	33	30.3
48					38.4	38.1	37.3	35.9	34	31.7	29.3
50						35.7	35.1	34	32.4	30.5	28.3
54						31.2	31.1	30.5	29.4	27.9	26.2
58							27.4	27.2	26.5	25.5	24.2
62								24.2	23.8	23.2	22.2
66									21.4	21	20.3
70									19.2	19	18.5
74										17.1	16.8
78											15.2

Boom length 60m

Boom angle 85°

Turntable counterweight 110t

Car-body counterweight 40t

Superlift mast radius 13m

Superlift counterweight radius 16m

superlift counterweight 230t

	Tower jib length (m)										
Radius (m)	24	30	36	42	48	54	60	66	72	78	84
16	151.5										
18	140.7	126.1									
20	129.2	118	105.9	92							



22	117.8	109.5	99.9	89.8	79.3						
24	106.8	100.8	93.5	85.2	76.6	67.4					
26	96.6	92.4	86.9	80.4	73.2	65.8	58.4				
28	87.3	84.4	80.4	75.4	69.5	63.2	57.1	50.3	43.4		
30		77	74.2	70.4	65.6	60.3	55	49.6	43.3	37.6	
32		70.1	68.3	65.5	61.8	57.4	52.8	48	43.1	37.5	32.8
34		63.9	62.8	60.8	57.9	54.3	50.5	46.2	41.8	37.3	32.7
36			57.6	56.3	54.2	51.3	48.1	44.4	40.4	36.5	32.5
38			52.9	52.1	50.6	48.3	45.7	42.5	39	35.5	32
40				48.2	47.1	45.4	43.3	40.6	37.5	34.3	31.1
42				44.5	43.9	42.6	40.9	38.7	36	33.1	30.2
44				41.2	40.8	39.9	38.6	36.8	34.4	31.9	29.2
46					38	37.4	36.4	34.9	32.9	30.7	28.3
48					35.3	35	34.2	33	31.3	29.4	27.3
50					32.8	32.7	32.2	31.3	29.8	28.2	26.2
54						28.6	28.4	27.9	26.9	25.7	24.2
58							25	24.8	24.2	23.4	22.2
62								22.1	21.7	21.1	20.3
66									19.4	19.1	18.5
70									17.4	17.2	16.7
74										15.4	15.2
78											13.7

Boom length 66m

Boom angle 85°

Turntable counterweight 110t

Car-body counterweight 40t





Superlift mast radius 13m

Superlift counterweight radius 16m

superlift counterweight 230t

Radius (m)	Tower jib length (m)										
	24	30	36	42	48	54	60	66	72	78	84
16	133.9										
18	125.4	112.3									
20	116.1	105.8	94.9								
22	106.6	98.7	89.9	81							
24	97.4	91.4	84.5	77.1	69.5	61.5					
26	88.7	84.3	78.9	72.9	66.5	59.9	53.5				
28	80.7	77.4	73.4	68.6	63.2	57.6	52.1	46.4			
30		71	68	64.3	59.9	55.1	50.3	45.4	40.3	35.1	
32		65	62.8	60	56.5	52.4	48.3	44	39.6	35	30.7
34		59.5	58	55.9	53.1	49.7	46.2	42.4	38.4	34.6	30.6
36			53.4	51.9	49.7	47	44	40.7	37.2	33.7	30.3
38			49.2	48.2	46.5	44.4	41.9	39	35.8	32.6	29.5
40			45.3	44.7	43.5	41.8	39.7	37.3	34.5	31.6	28.7
42				41.4	40.6	39.2	37.5	35.5	33	30.5	27.8
44				38.4	37.8	36.8	35.5	33.8	31.6	29.3	26.9
46					35.2	34.5	33.4	32	30.2	28.2	26
48					32.8	32.3	31.5	30.4	28.8	27	25.1
50					30.6	30.3	29.7	28.7	27.4	25.9	24.1
54						26.5	26.2	25.7	24.7	23.6	22.2
58							23.2	22.9	22.2	21.4	20.4
62								20.4	19.9	19.4	18.6
66								18.1	17.9	17.5	16.9
70									16	15.7	15.3
74										14.2	13.8
78											12.5



Boom length 72m

Boom angle 85°

Turntable counterweight 110t

Car-body counterweight 40t

Superlift mast radius 13m

Superlift counterweight radius 16m

superlift counterweight 230t

Radius (m)	Tower jib length (m)										
	24	30	36	42	48	54	60	66	72	78	84
18	113.6	102									
20	105.7	96.4	86.8								
22	97.5	90.2	82.4	74.4							
24	89.5	83.9	77.6	70.9	64.1						
26	81.9	77.6	72.6	67.2	61.4	55.5	50				
28	74.8	71.5	67.6	63.3	58.4	53.4	48.4	43.6			
30	68.3	65.7	62.8	59.3	55.3	51	46.7	42.3	38		
32		60.3	58.1	55.4	52.2	48.6	44.8	40.9	36.9	33.2	29.2
34		55.4	53.7	51.7	49.1	46.1	42.8	39.4	35.8	32.3	29
36			49.6	48.1	46	43.6	40.8	37.8	34.6	31.4	28.3
38			45.8	44.7	43.1	41.1	38.8	36.2	33.3	30.5	27.6
40			42.3	41.5	40.3	38.7	36.7	34.5	32	29.4	26.8
42				38.5	37.6	36.3	34.7	32.9	30.7	28.4	25.9
44				35.7	35.1	34.1	32.8	31.2	29.3	27.3	25.1
46					32.7	32	30.9	29.6	28	26.2	24.2
48					30.5	30	29.1	28.1	26.6	25	23.3
50					28.4	28.1	27.4	26.5	25.3	23.9	22.3
54						24.6	24.2	23.7	22.8	21.8	20.5
58							21.4	21.1	20.5	19.7	18.7
62								18.7	18.3	17.8	17
66								16.6	16.4	16	15.4
70									14.6	14.4	14



74										12.9	12.6
78											11.3
82											10.2

Boom length 78m

Boom angle 85°

Turntable counterweight 110t

Car-body counterweight 40t

Superlift mast radius 13m

Superlift counterweight radius 16m

superlift counterweight 230t

Radius (m)	Tower jib length (m)										
	24	30	36	42	48	54	60	66	72	78	84
18	100.8										
20	94.6	86.1	77.2								
22	88	81.1	73.9	66.8							
24	81.4	75.9	70	63.9	57.8						
26	75	70.6	65.8	60.8	55.5	50.3					
28	69	65.4	61.6	57.5	53	48.4	43.9	39.6			
30	63.4	60.5	57.5	54.1	50.3	46.4	42.4	38.5	34.6		
32		55.9	53.5	50.7	47.6	44.2	40.7	37.2	33.7	30.3	
34		51.6	49.6	47.5	44.9	42.1	39	35.9	32.7	29.5	26.5
36		47.6	46.1	44.3	42.2	39.9	37.2	34.5	31.6	28.7	25.9
38			42.7	41.4	39.7	37.7	35.4	33.1	30.4	27.8	25.2
40			39.6	38.5	37.2	35.5	33.6	31.6	29.2	26.9	24.5
42				35.9	34.8	33.5	31.9	30.1	28	25.9	23.7
44				33.4	32.6	31.5	30.2	28.6	26.8	24.9	22.9
46				31.1	30.5	29.6	28.5	27.2	25.6	23.9	22.1
48					28.5	27.8	26.9	25.8	24.4	22.9	21.2



50					26.6	26.1	25.3	24.4	23.2	21.9	20.4
54						23	22.5	21.9	21	20	18.7
58							19.9	19.5	18.8	18.1	17.1
62							17.6	17.4	16.9	16.3	15.6
66								15.5	15.1	14.7	14.1
70									13.5	13.2	12.8
74										11.9	11.5
78											10.4
82											9.3

Boom length 84m

Boom angle 85°

Turntable counterweight 110t

Car-body counterweight 40t

Superlift mast radius 13m

Superlift counterweight radius 16m

superlift counterweight 230t

Radius (m)	Tower jib length (m)										
	24	30	36	42	48	54	60	66	72	78	84
18	91.5										
20	86.3	78.6									
22	80.7	74.3	67.8								
24	74.9	69.8	64.3	58.8	53.3						
26	69.4	65.2	60.7	56	51.2	46.5					
28	64.1	60.6	56.9	53.1	48.9	44.8	40.6				
30	59.1	56.2	53.2	50.1	46.5	42.9	39.3	35.7	32.1		
32		52.1	49.7	47	44.1	41	37.7	34.5	31.3	28.2	
34		48.2	46.2	44.1	41.6	39	36.1	33.3	30.3	27.5	24.6
36		44.7	43	41.3	39.2	37	34.5	32	29.3	26.7	24



38			39.9	38.5	36.9	35	32.8	30.7	28.2	25.8	23.4
40			37.1	36	34.6	33	31.2	29.3	27.1	24.9	22.7
42				33.6	32.4	31.1	29.6	27.9	26	24	22
44				31.3	30.4	29.3	28	26.6	24.8	23.1	21.2
46				29.2	28.5	27.6	26.4	25.2	23.7	22.1	20.4
48					26.6	25.9	24.9	23.9	22.6	21.2	19.6
50					24.9	24.3	23.5	22.6	21.5	20.3	18.9
54						21.5	20.9	20.3	19.4	18.4	17.3
58							18.5	18.1	17.4	16.7	15.8
62							16.4	16.1	15.6	15	14.3
66								14.4	14	13.5	12.9
70									12.5	12.2	11.7
74										10.9	10.5
78										9.8	9.4
82											8.5

## 10. Goose head jib superlift working condition (SHJ)

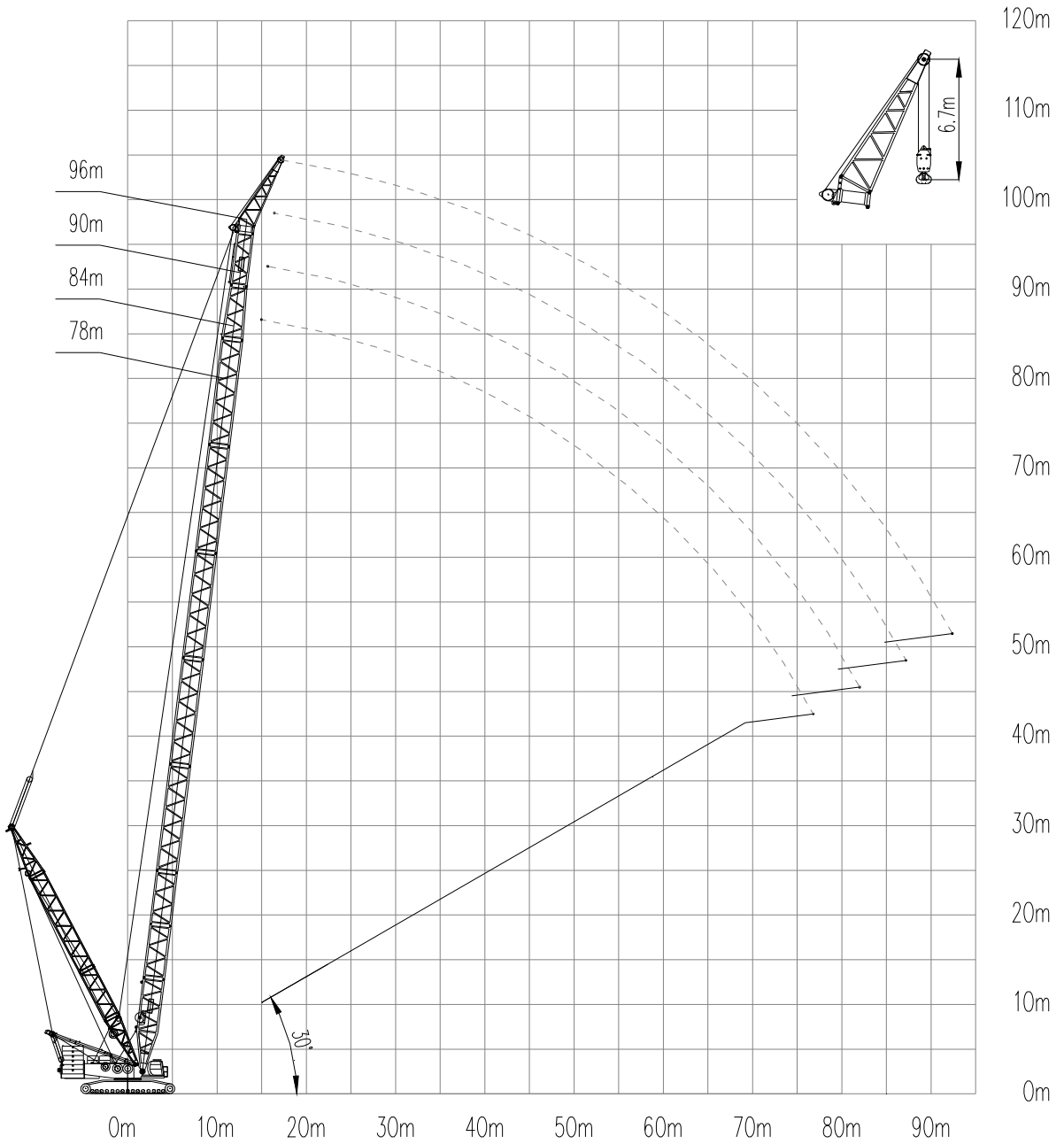



Turntable counterweight 150t+Car-body counterweight 40t,

superlift mast radius 15m, superlift counterweight 0t

	Boom length (m)			
Radius (m)	78	84	90	96
16	116.6	108.8		
18	103.5	100.5	97.3	91.7
20	91.7	89.5	87.3	84.3
22	81.9	80.0	78.0	76.0
24	73.6	72.0	70.2	68.3
26	65.9	65.0	63.5	61.8
28	59.4	58.6	57.5	56.0
30	53.9	53.1	52.2	50.9
32	49.0	48.2	47.3	46.4
34	44.6	44.0	43.2	42.3
36	40.8	40.2	39.4	38.6
38	37.4	36.7	36.0	35.2
40	34.4	33.7	33.0	32.1
42	31.7	31.1	30.3	29.5
44	29.2	28.6	27.8	27.0
46	27.0	26.4	25.6	24.8
48	25.0	24.4	23.6	22.7
50	23.2	22.5	21.7	20.9
54	19.9	19.2	18.4	17.5
58	17.1	16.4	15.6	14.7
62	14.7	14.0	13.2	12.3
66	12.5	11.9	11.1	10.2
70	10.6	10.0	9.2	8.3
74	9.0	8.3	7.5	6.6
78		6.8	6.0	



### 11. TBM jib superlift working condition (SHFS)

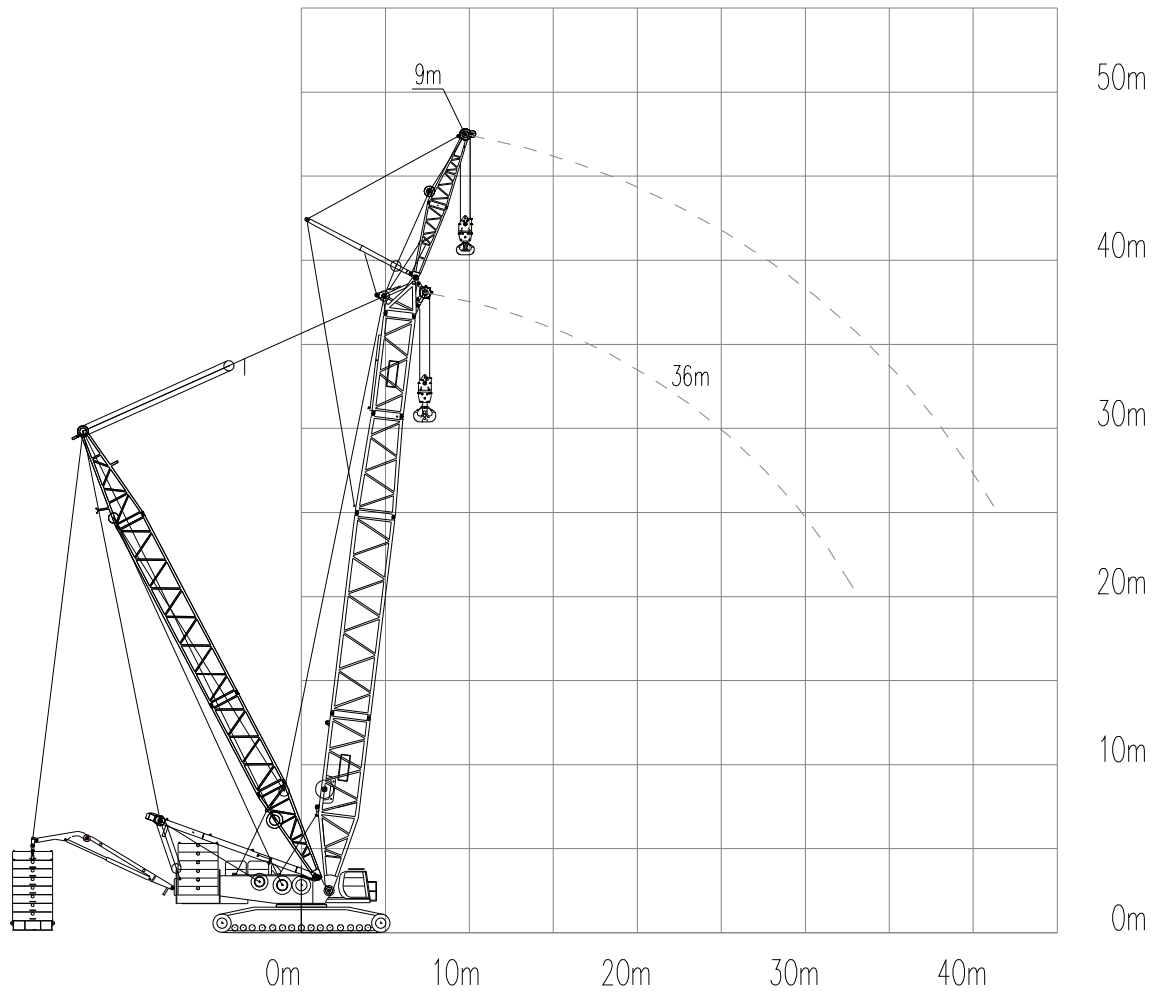





Boom length 36m

Jib length 9m

Jib angle 10°

Turntable counterweight 110t

Car-body counterweight 40t

Superlift mast radius 13m

Superlift counterweight radius 16m

superlift counterweight 230t

Boom angle	Main hook radius	Main hook load	Aux. hook radius	Aux. hook load	Total load of main and aux. hooks
°	(m)	(t)	(m)	(t)	(t)
82.0	8	479.2	10.5	245.4	364.0
80.4	9	479.5	11.8	243.8	356.9
78.7	10	480.1	13.1	242.5	350.1
77.1	11	481.1	14.3	236.2	343.8
75.5	12	456.2	15.6	223.1	337.9
73.8	13	420.6	16.8	211.4	332.3
72.1	14	388.6	18.1	200.9	327.1
70.4	15	359.6	19.4	191.5	314.1
68.7	16	334.5	20.6	182.9	292.5
66.9	17	312.2	21.9	175.1	273.3
65.2	18	291.9	23.1	168.1	256.2
63.4	19	273.7	24.4	161.6	240.7
61.5	20	257.2	25.6	155.6	226.7
57.8	22	228.5	28.2	145.0	201.3
53.8	24	204.1	30.7	135.9	180.0
49.6	26	182.7	33.2	128.1	161.9
45.1	28	164.2	35.6	121.3	146.2
40.2	30	148.0	38.1	113.7	132.4
34.7	32	133.4	40.6	102.7	120.0



## VI. Transport plan

Table 1 Transport weight and dimensions for crane main parts

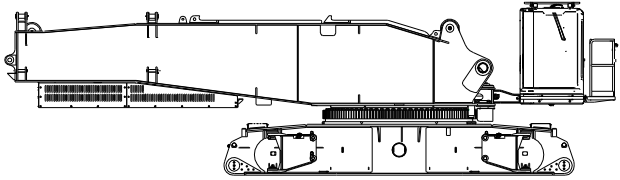
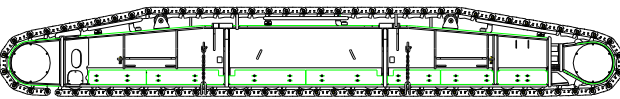
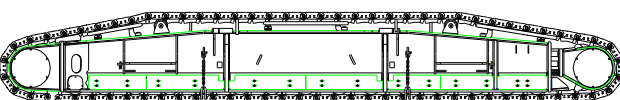
No.	Part name and diagram	Qty.		L /m	W /m	H /m	W /t	Remark
1	Basic machine	Qty.	1	12.03	3.00	3.41	47.9	Include turntable, car-body (with 4 outrigger pads), cab and etc.
								
2	Left track frame	Qty.	1	10.71	1.62	1.54	30.9	
								
3	Right track frame	Qty.	1	10.71	1.62	1.54	30.9	
								
4	Mast assy.	Qty.	1	11.14	2.21	1.14	9.8	Include mast,



No.	Part name and diagram	L /m	W /m	H /m	W /t	Remark
						main luffing pulley block, main luffing system and wire rope.
5	Hoist winch      Qty.    1 	2.41	1.90	1.13	9.56	Include main/aux. hoist rope
6	Central counterweight      Qty.    2 	6.08	1.64	0.84	20	
7	Turntable counterweight frame      Qty.    2 	2.62	2.68	2.03	15	Include counterweight locking chain assy.
8	Counterweight slab      Qty.    12 	2.38	2.10	0.58	10	
9	Outrigger      Qty.    2 	2.53	0.98	1.20	2.49	Include outrigger

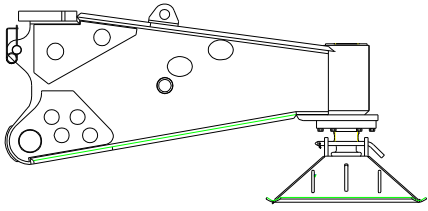
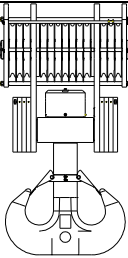
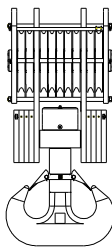
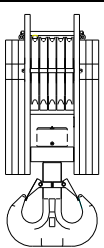
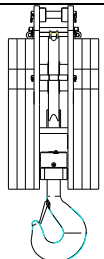

No.	Part name and diagram	L /m	W /m	H /m	W /t	Remark		
						pads		
10	350t capacity hook block	Qty.	1	1.44	0.87	2.82	6.16	
								
11	260t capacity hook block	Qty.	1	1.02	0.87	2.34	3.94	
								
12	160t capacity hook block	Qty.	1	0.87	0.76	2.13	3.91	
								
13	50t capacity hook block	Qty.	1	0.64	0.76	1.84	2.43	
								

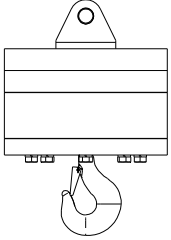
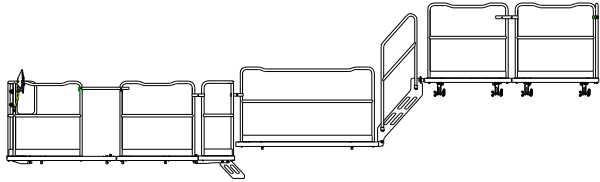
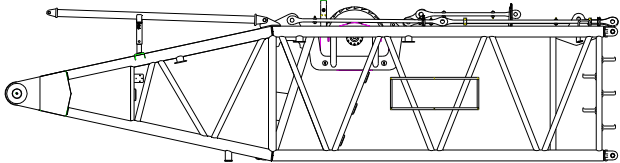
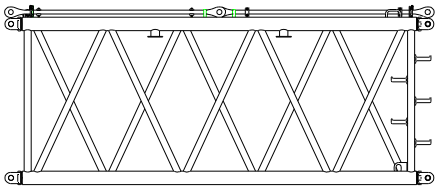
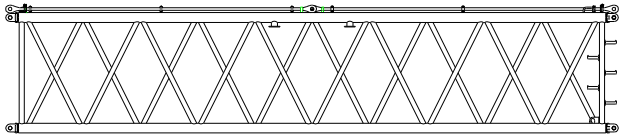

No.	Part name and diagram		L /m	W /m	H /m	W /t	Remark
14	16t capacity hook block	Qty. 1	0.60	0.60	0.87	0.88	
							
15	Catwalk	Qty. 1	—	—	—	0.48	Transport after disassembly
							
16	Boom butt.	Qty. 1	10.80	3	2.86	13.34	Include boom backstop cylinder, tower jib luffing winch and rope, some pendant
							
17	6m heavy boom insert	Qty. 2	6.18	3	2.55	3.25	Include pendant
							
18	12m heavy boom insert I	Qty. 1	12.18	3	2.55	5.79	Include pendant
							

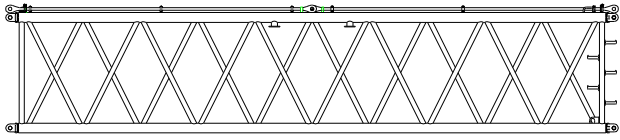
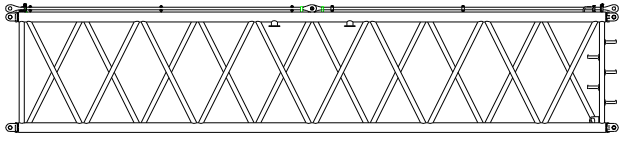
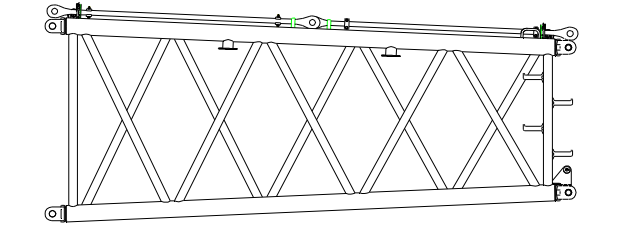
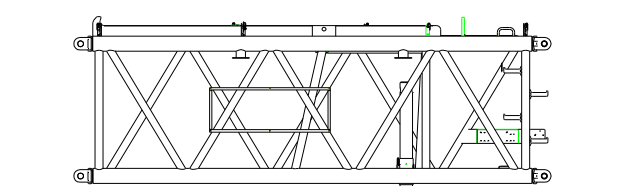

No.	Part name and diagram		L /m	W /m	H /m	W /t	Remark
19	12m heavy boom insert II	Qty. 1	12.18	3	2.55	5.82	Include pendant
							
20	12m light boom insert	Qty. 2	12.18	3	2.55	5.27	Include pendant
							
21	6m boom transition section	Qty. 1	6.18	3	2.56	2.62	Include pendant
							
22	6m light boom insert	Qty. 1	6.18	2.5	2.2	3.50	Include pendant and tower jib luffing pulley block
							
23	Boom head	Qty. 1	2.57	2.59	2.72	3.62	Include pendant

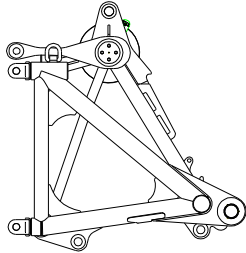
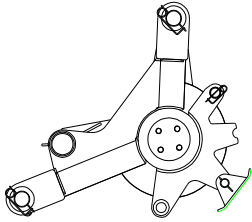
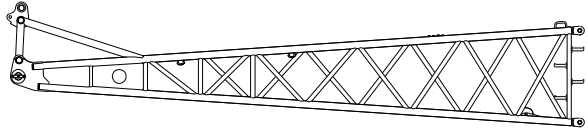
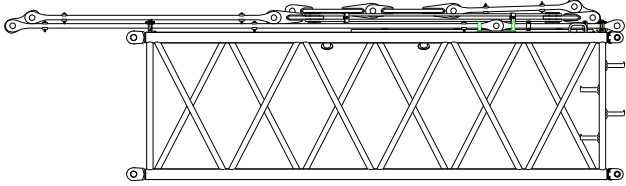
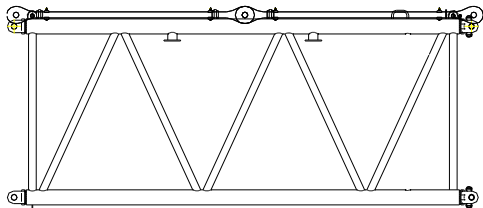

No.	Part name and diagram	L /m	W /m	H /m	W /t	Remark		
								
24	Boom sheave block	Qty.	1	1.39	1.67	1.2	1.57	
								
25	Tower jib butt.	Qty.	1	10.81	2.53	2.31	3.25	
								
26	6m tower jib insert A	Qty.	1	7.68	2.44	2.25	3.05	Include pendant balance beam
								
27	6m tower jib insert B	Qty.	2	6.16	2.44	2.01	1.75	Include pendant
								
28	12m tower jib insert A	Qty.	1	12.16	2.44	2.01	3.13	Include pendant

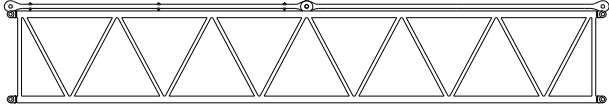
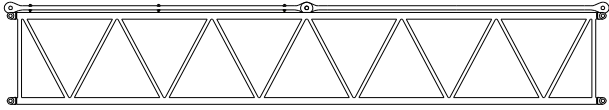
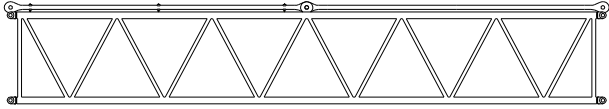
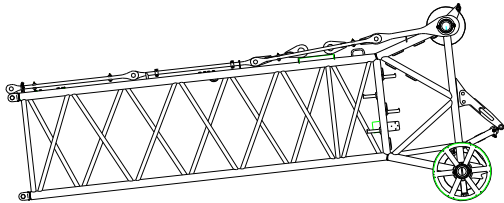
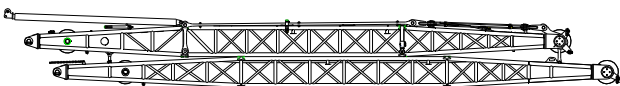

No.	Part name and diagram	L /m	W /m	H /m	W /t	Remark		
								
29	12m tower jib insert B	Qty.	2					
		12.16	2.44	2.01	2.97	Include pendant		
30	12m tower jib center hitch section	Qty.	1					
		12.16	2.44	2.01	3.14	Include pendant		
31	Tower jib top	Qty.	1					
		8.51	2.44	3.35	4.46	Include pendant		
32	Tower jib front/rear struts	Qty.	1					
		16.25	2.61	2.06	8.73	Include pendant		
33	Goose head jib	Qty.	1	10.05	2.44	2.91	3.8	



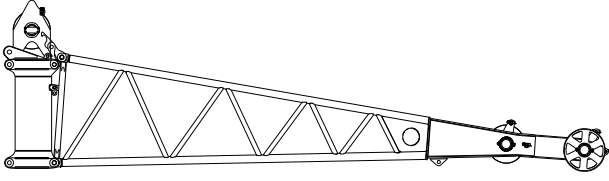
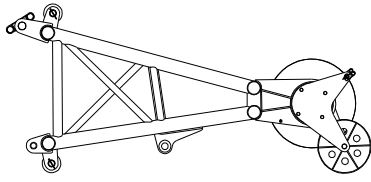
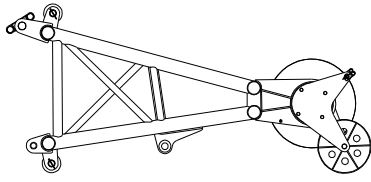
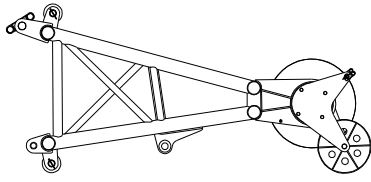
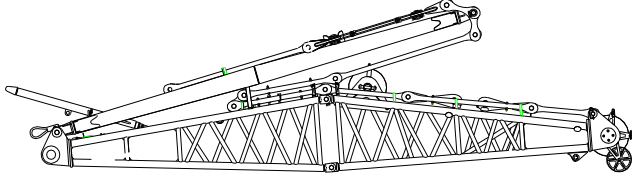
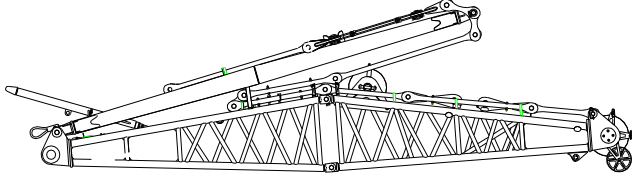

No.	Part name and diagram	L /m	W /m	H /m	W /t	Remark						
												
34	<table border="1" style="width: 100%; border-collapse: collapse;"> <tr> <td data-bbox="197 573 692 651">Single top</td> <td data-bbox="692 573 788 651">Qty.</td> <td data-bbox="788 573 863 651">1</td> </tr> <tr> <td colspan="3" data-bbox="197 651 863 922" style="text-align: center;">  </td> </tr> </table>	Single top	Qty.	1				2.67	1.53	1.25	0.51	
Single top	Qty.	1										
												
35	<table border="1" style="width: 100%; border-collapse: collapse;"> <tr> <td data-bbox="197 922 692 1001">Fixed jib</td> <td data-bbox="692 922 788 1001">Qty.</td> <td data-bbox="788 922 863 1001">1</td> </tr> <tr> <td colspan="3" data-bbox="197 1001 863 1270" style="text-align: center;">  </td> </tr> </table>	Fixed jib	Qty.	1				10.12	3	2.78	5.36	Include fixed jib top, strut, front/rear pendants, backstop rod and etc., optional configuration
Fixed jib	Qty.	1										
