

IHI

CCH 1500

Fully Hydraulic Crawler Crane

Lifting capacity 150 metric tons



IHI Construction Machinery Limited

Luffing Jib Crane evolved to equip "Auxiliary Jib"

Luffing Jib Crane

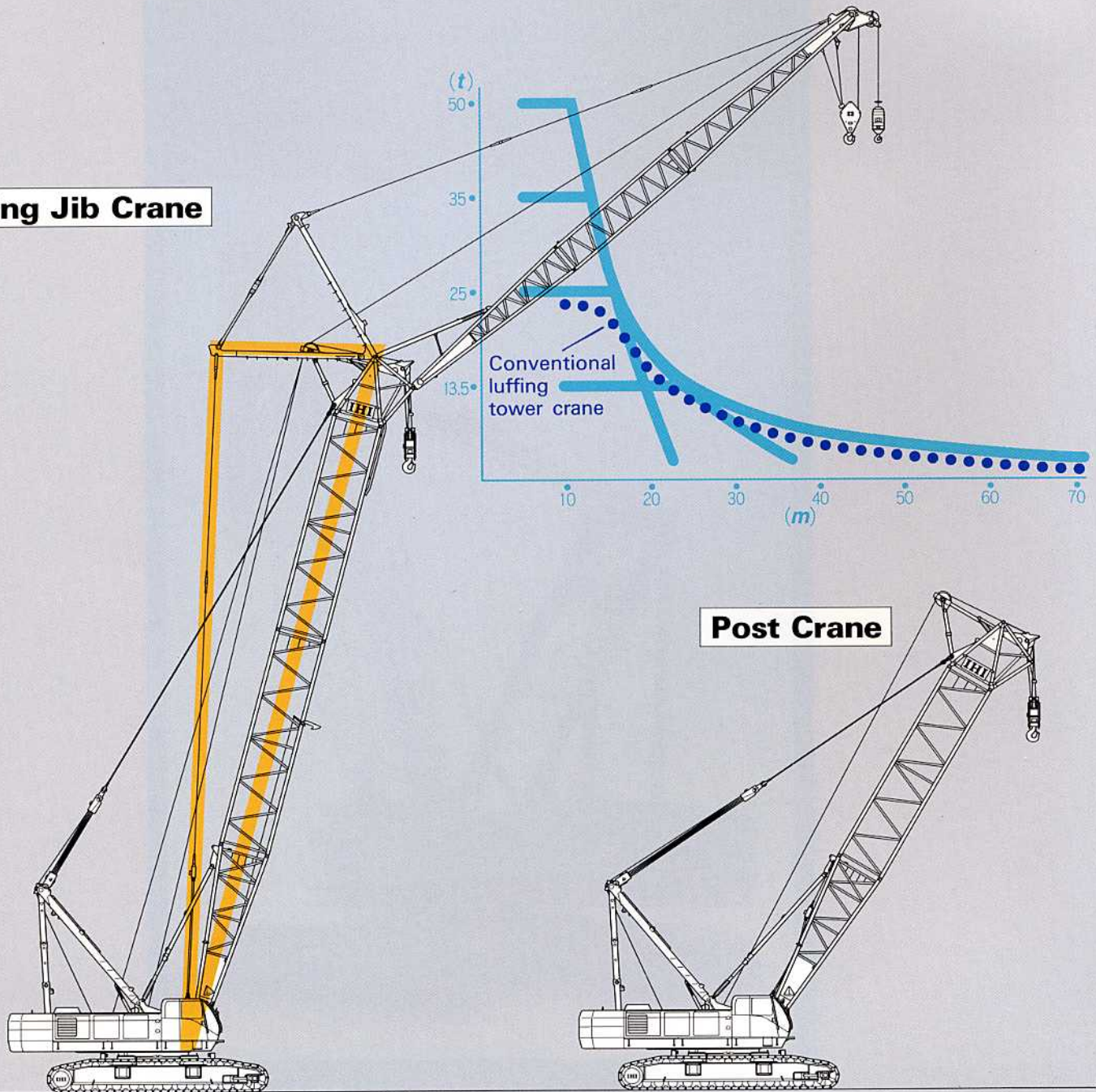

Post Crane

Selections are available from:
1) 50-ton lifting with Post
2) 25-ton lifting with Luffing Jib
3) 13.5-ton lifting with Auxiliary Jib
Simultaneous lifting by Post and Auxiliary Jib is not permitted.

Middle Equalizer for Luffing Jib lifting is tentatively stowed on inner post when the Luffing Jib is dismantled.

General Dimensions

Unit: mm

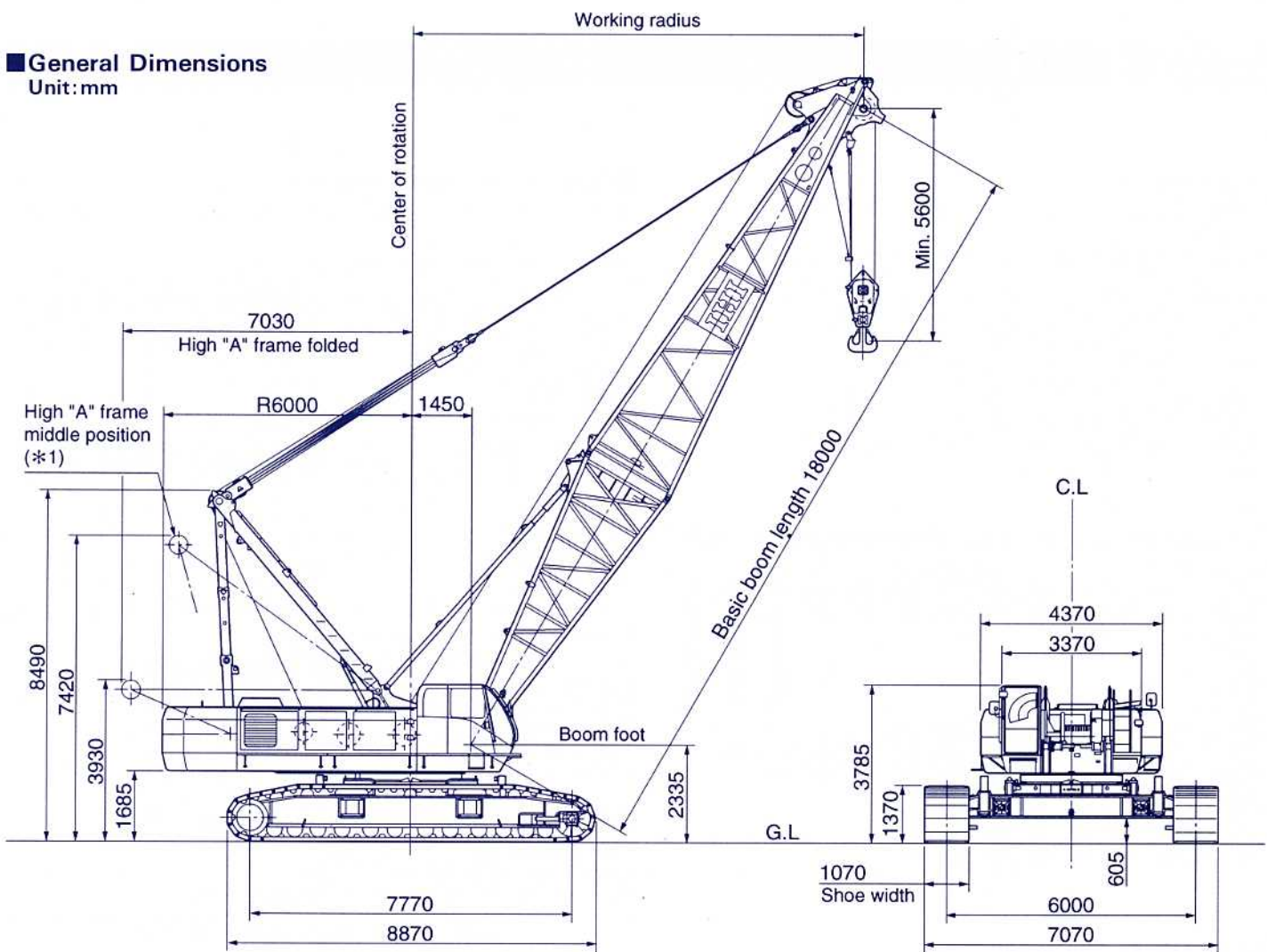

Specifications

Performance	
Swing speed	1.7min ⁻¹ (1.7rpm) [Constant swing speed 0.6min ⁻¹ (0.6rpm)---optional]
Travel speed	※ 1.1/0.7km/h
Gradability	30%(16.7°)
Engine	
Make	HINO MOTOR
Model	K13C-TJ (with turbo) diesel engine
Type	4-cycle, water cooled, straight 6-cylinder, direct injection
Rated output	235kw/2000min ⁻¹ (320PS/2000rpm)
Total piston displacement	12.882 ℓ
Fuel tank capacity	450 ℓ
Battery	DC12V×150AH×2pcs.
Main hoist system (Front left axle, also used for hoisting tower jib)	
Hydraulic motor	Variable displacement axial piston type
Reduction gear	Two-stage planetary gear
Hoist drum	Single drum driven independently by hydraulic motor, lebus grooved drum
Clutch	Internal expanding band type
Brake	External contracting band type
Drum lock	Ratchet lock
Aux. hoist system (Rear left axle)	
Hydraulic motor	Variable displacement axial piston type
Reduction gear	Two-stage planetary gear
Hoist drum	Single drum driven independently by hydraulic motor, lebus grooved drum
Clutch	Internal expanding band type
Brake	External contracting band type
Drum lock	Ratchet lock
Boom hoist system (Rear right axle, also used for hoisting tower post)	
Hydraulic motor	Variable displacement axial piston type
Reduction gear	Three-stage planetary gear
Hoist drum	Dual drums driven independently by hydraulic motor, lebus grooved drum
Brake	Wet type multi-disk
Drum lock	Ratchet lock

※ The travel speed changes depending on the load.

Standard equipment

- **Instrument for crane**
 - Engine tachometer (Hour meter)
 - Hydraulic oil pressure gauge (for control circuit)
 - Fuel level gauge
 - Engine coolant thermo indicator (indicated bar graph in OK monitor)
 - **Lighting for crane**
 - 2-Work light (24v×80w)
 - 1-Room light (24v×10w)
 - **Safety devices**
 - Automatic stop for hook overwinding
 - Automatic stop for boom overwinding
 - 2nd boom stop device (non-resettable)
 - Telescopic boom limit stop
 - Swing lock
 - Main and auxiliary drum lock
 - Boom hoist drum lock
 - Safety valve for hydraulic circuit
 - Clutch engage pin on main and auxiliary winch
 - Counter balance valve
 - Control lever locking device
 - Traction lever lock
 - Automatic braking system
 - Engine start voice alarm
 - **Other standard accessories**
 - Front windshield wipers (intermittent, w/washer)
 - Roof wipers (intermittent, w/washer)
 - Sunvisor
 - Sun shade
 - Storage pouch
 - Tool box
 - Reclining operator's seat
 - Floor mat
 - Steps for operator's cab
 - Radio
 - Cigarette lighter
 - Ash tray
- Large rear view mirrors (right/left)
Signal horn
Electric fuel filling pump
Swing warning flasher & alarm
Travel warning alarm
High "A" frame erecting device
Low-noise cab
Bronze tinted glass
Wire mesh boom workway (for inner boom)
Foot rest
Electric type engine throttle
Foot pedal-type engine throttle
Ultra low-speed control (w/selector switch for coupling with engine speed or independent)
Hydraulic assist brake for main and aux. winch
Winch mode selector for main and aux. winch
Rope guide roller on outer boom
Plug socket
Loud speaker
Dial-type winch speed adjustment device (main, aux. and boom)
Pump power shift device
Emergency engine stop switches
Foot pin cylinder device
Fulcrum plate for erecting attachment (also used as climbing step to operator's cabin)

Optional equipment

- Moment limiter (* 2)
- Optional boom canthus setting device (included in moment limiter)
- Automatic stop system (activated when near the marginal angle or when load is 90%)
- Built-in type air conditioner
- Large-sized storage bin

(* 1) High "A" frame middle position when mast is in use.

(* 2) Optional depend on region

Specifications

Max. Lifting capacity × working radius	150metric tons × 5.0m	
Max. boom length	84m	
Max. boom length (main + jib)	103m (72m boom + 31m jib)	
Rope speed	Main drum hoist/lowering	* 110~55 / 55~28m / min
	Aux. drum hoist/lowering	* 110~55 / 55~28m / min
	Boom drum hoist/lowering	* 32~14m / min × 2
Part line	Hook block capacity × Part line	150ton × 12
	Hook block capacity × Part line	13.5ton × 1
	Boom drum hoist	18
Counterweight	64ton	
Total operating weight (with 18m boom)	161ton	
Average ground bearing pressure	89kPa (0.91kgf/cm ²)	

* The rope speed changes depending on the load.

Combination of Boom and Jib (●: Available combination)

Jib length (m)	Boom length (m)											
	18	21	24	27	30	33	36	39	42	45	48	51
Auxiliary	●	●	●	●	●	●	●	●	●	●	●	●
13										●	●	●
19										●	●	●
25										●	●	●
31										●	●	●

Jib length (m)	Boom length (m)										
	54	57	60	63	66	69	72	75	78	81	84
Auxiliary	●	●	●	●	●	●	●	●	●	●	
13	●	●	●	●	●	●	●				
19	●	●	●	●	●	●	●				
25	●	●	●	●	●	●	●				
31	●	●	●	●	●	●	●				

Wire Rope

Place of use	Rope diameter (mm)	Guaranteed strength (ton)	Rope type
Main drum	φ28	70.2	P·S (19) + 39 × P.7
Boom hoist	φ22	36.3	IWRC6 × WS (31)
Boom suspension	φ34	104.0	IWRC6 × P·WS (36)
Aux. drum	φ28	70.2	P·S (19) + 39 × P.7
Jib suspension	φ28	59.7	IWRC6 × Fi (29)
Jib strut suspension	φ31.5	74.9	IWRC6 × Fi (29)

Note: Wire rope length to be determined according to the boom length.

Crane boom composition

The following tables show standard combinations for each boom and jib length.

Boom standard combination

Boom length (m)	18	21	24	27	30	33	36	39	42	45	48	51
7.5m inner	1	1	1	1	1	1	1	1	1	1	1	1
3.0m insert	—	1	2	1	1	2	1	2	1	1	2	1
6.0m insert	—	—	—	1	—	—	1	1	2	1	1	2
9.0m insert	—	—	—	—	1	1	1	1	1	2	2	2
10.5m outer	1	1	1	1	1	1	1	1	1	1	1	1

Boom length (m)	54	57	60	63	66	69	72	75	78	81	84
7.5m inner	1	1	1	1	1	1	1	1	1	1	1
3.0m insert	1	2	1	1	2	1	1	2	1	1	2
6.0m insert	1	1	2	1	1	2	1	1	2	1	1
9.0m insert	3	3	3	4	4	4	5	5	5	6	6
10.5m outer	1	1	1	1	1	1	1	1	1	1	1

Note: Installation of mast is required for boom length exceeding 69m.

Jib standard combination

Jib length (m)	13	19	25	31
6.5m inner	1	1	1	1
6.0m insert	—	1	2	3
6.5m outer	1	1	1	1

* Contact IHI if other combinations required.

Additional counterweight (optional)

Counterweight	94t
Total operating weight (with 18m boom)	191t
Average ground bearing pressure	108kpa (1.10kg/cm ²)

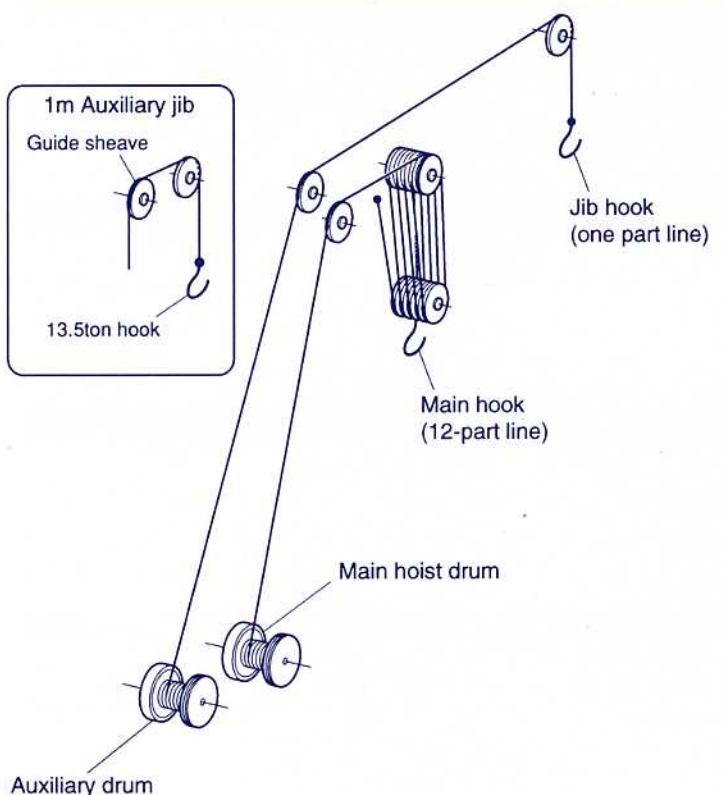
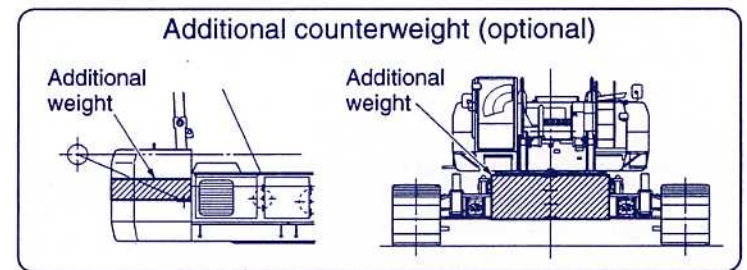

Working range (No load condition)

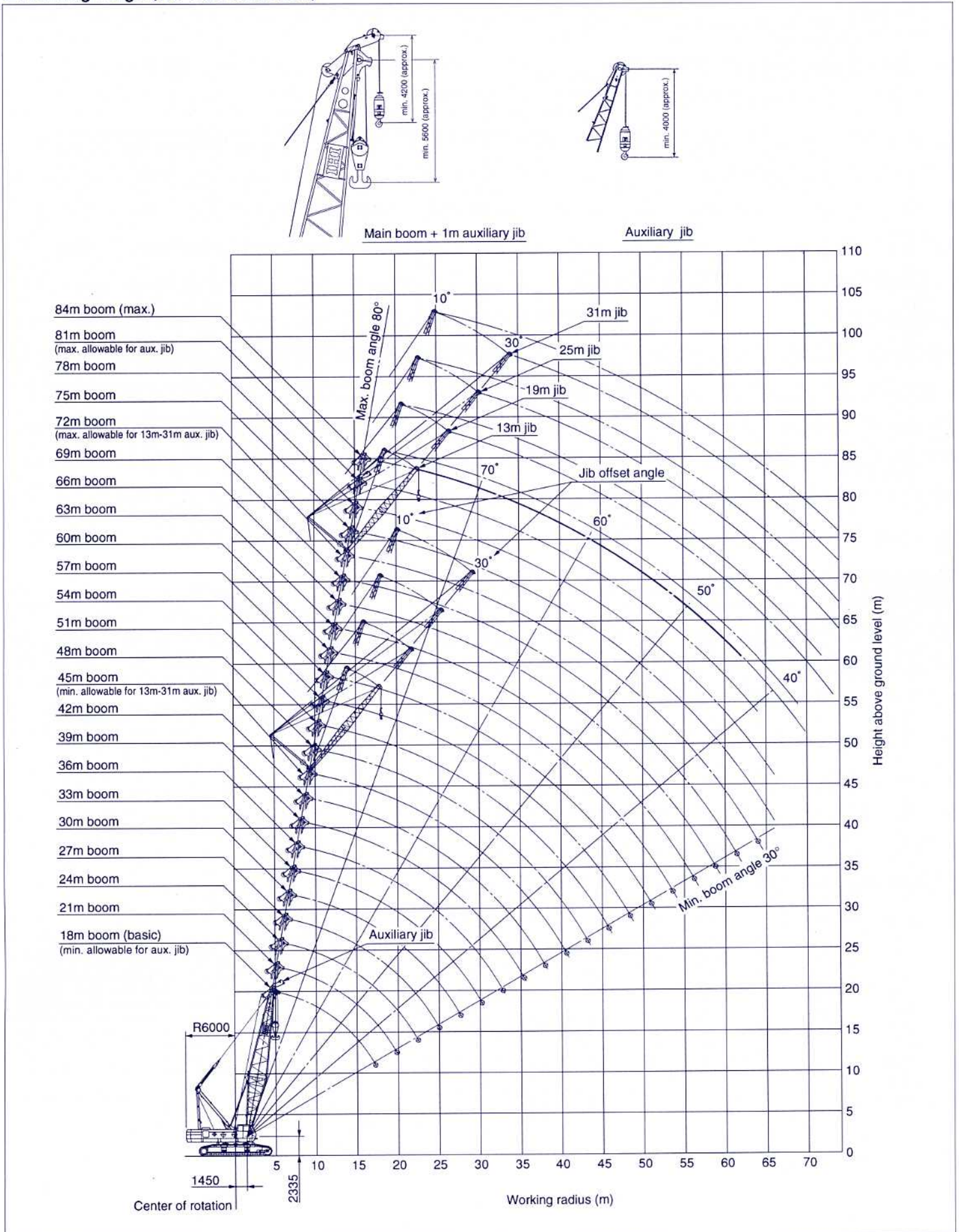



■ Main boom rated lifting loads (64ton counterweight)

(Unit: metric ton)

Boom length (m) Working radius (m)	18.0	21.0	24.0	27.0	30.0	33.0	36.0	39.0	42.0	45.0	48.0	51.0	54.0	57.0	60.0	
5.0	5.0m × 150.0	5.6m × 142.0														
6.0	146.1	142.0	6.1m × 134.0	6.6m × 125.0												
7.0	137.3	137.2	134.0	125.0	7.2m × 118.0	7.7m × 108.0										
8.0	113.3	113.2	113.1	113.0	112.9	108.0	8.2m × 98.0	8.7m × 92.0								
9.0	94.6	94.5	94.4	94.3	94.2	94.1	94.0	92.0	9.2m × 84.0	9.8m × 80.0						
10.0	80.9	80.8	80.7	80.6	80.5	80.4	80.3	80.2	80.1	80.0	10.3m × 77.0	10.8m × 73.0	11.3m × 68.0	11.9m × 62.0		
12.0	63.2	63.1	63.0	62.9	62.8	62.7	62.6	62.5	62.4	62.3	62.2	62.0	61.9	61.7	12.4m × 59.1	
14.0	50.7	50.6	50.5	50.4	50.3	50.3	50.2	50.1	50.0	49.9	49.8	49.7	49.6	49.5	49.4	
16.0	42.3	42.2	42.1	42.0	41.9	41.8	41.7	41.6	41.5	41.4	41.3	41.1	41.0	40.9	40.7	
18.0	17.2m × 38.7	36.2	36.0	35.9	35.8	35.7	35.6	35.4	35.3	35.2	35.1	35.1	35.0	34.9	34.9	
20.0		19.8m × 31.8	31.2	31.1	31.0	30.8	30.7	30.6	30.4	30.3	30.3	30.2	30.2	30.1	30.1	
22.0			27.4	27.3	27.2	27.1	27.0	26.8	26.7	26.6	26.5	26.4	26.4	26.3	26.2	
24.0			22.4m × 26.8	24.2	24.1	24.0	23.9	23.7	23.6	23.5	23.4	23.3	23.1	23.0	22.9	
26.0				25.0m × 22.9	21.6	21.5	21.4	21.3	21.2	21.1	21.0	20.8	20.7	20.5	20.4	
28.0					27.6m × 19.9	19.4	19.3	19.2	19.1	19.0	18.9	18.7	18.6	18.4	18.3	
30.0						17.5	17.5	17.4	17.3	17.2	17.0	16.9	16.7	16.6	16.4	
32.0							30.2m × 17.4	16.0	15.9	15.8	15.7	15.5	15.4	15.2	14.9	
34.0								32.8m × 15.4	14.5	14.5	14.4	14.2	14.1	13.9	13.5	
36.0									35.4m × 13.8	13.4	13.3	13.1	12.9	12.8	12.4	
38.0										38.0m × 12.3	12.2	12.0	11.8	11.7	11.3	
40.0											11.3	11.1	10.9	10.7	10.3	
42.0											40.6m × 11.0	10.2	10.0	9.8	9.5	
44.0												43.2m × 9.8	9.3	9.1	8.7	
46.0													45.8m × 8.7	8.4	8.0	
48.0														7.7	7.4	
50.0														48.4m × 7.6	7.0	
52.0															51.0m × 6.7	6.3
54.0																53.6m × 5.9

Boom length (m) Working radius (m)	63.0	66.0	69.0	72.0	75.0	78.0	81.0	84.0
12.0	12.9m × 54.0	13.4m × 48.0	13.9m × 44.0					
14.0	49.3	48.0	44.0	14.5m × 39.0	15.0m × 34.5	15.5m × 31.0		
16.0	40.6	40.5	40.3	39.0	34.5	31.0	16.0m × 27.5	16.5m × 24.0
18.0	34.8	34.7	34.7	34.6	34.2	31.0	27.5	24.0
20.0	30.0	30.0	29.9	29.9	29.6	29.3	27.5	24.0
22.0	26.1	26.1	26.0	25.9	25.6	25.4	25.1	24.0
24.0	22.8	22.6	22.5	22.4	22.2	22.1	21.9	21.8
26.0	20.2	20.1	19.9	19.8	19.6	19.5	19.3	19.2
28.0	18.1	18.0	17.8	17.7	17.5	17.3	17.2	17.0
30.0	16.3	16.1	16.0	15.8	15.6	15.5	15.3	15.2
32.0	14.8	14.6	14.5	14.3	14.1	13.9	13.7	13.6
34.0	13.4	13.2	13.0	12.9	12.7	12.5	12.4	12.2
36.0	12.2	12.1	11.9	11.7	11.5	11.3	11.1	11.0
38.0	11.1	10.9	10.7	10.6	10.4	10.2	10.1	9.9
40.0	10.1	9.9	9.7	9.6	9.4	9.2	9.1	8.9
42.0	9.3	9.1	8.9	8.7	8.6	8.4	8.3	8.1
44.0	8.5	8.3	8.1	7.9	7.8	7.6	7.5	7.3
46.0	7.8	7.6	7.4	7.2	7.1	6.9	6.8	6.6
48.0	7.2	7.0	6.8	6.6	6.5	6.3	6.1	5.9
50.0	6.6	6.4	6.2	6.0	5.9	5.7	5.5	5.3
52.0	6.1	5.9	5.7	5.5	5.3	5.1	4.9	4.7
54.0	5.6	5.4	5.2	5.0	4.8	4.6	4.3	4.1
56.0	5.2	5.0	4.8	4.6	4.4	4.1	3.9	3.6
58.0	56.2m × 5.1	4.5	4.3	4.1	3.9	3.6	3.4	3.1
60.0		58.8m × 4.3	3.8	3.6	3.4	3.1	2.9	2.6
62.0			61.4m × 3.5	3.2	3.0	2.8	2.6	2.4
64.0				64.0m × 2.8	2.6	2.4	2.1	
66.0					2.2	2.0		

Notes

- Above rated loads are based on the machine being operated on firm level ground, within 78% of tipping load at any point of 360° around the machine with forward stability factor of over 1.15.
- Working radius is horizontal distance from center of rotation to a vertical line through the center of gravity of the load.
- The weight of the slings, hook block(s) and auxiliary lifting devices must be considered to be a part of the load.
Hook block weight:
150ton hook block...2.40ton 100ton hook block...1.40ton
60ton hook block...1.20ton 50ton hook block...1.00ton
30ton hook block...1.00ton 13.5ton hook block...0.60ton
- Jib boom can be fitted to main boom in the following combinations.

Jib length(m)	Auxiliary	13.0	19.0	25.0	31.0
Boom length(m)	18.0~81.0	45.0~72.0	45.0~72.0	45.0~72.0	45.0~72.0

- When jib boom is fitted actual loads that can be lifted with main hook block should be reduced according to the below table (the weights include auxiliary hook block).

Jib length(m)	Auxiliary	13.0	19.0	25.0	31.0
Weight to be deducted(ton)	0.80	3.5	4.0	4.9	6.0

- High "A" Frame should be extended before working. Extend the "A" frame to the highest position when there is no mast. Extend the "A" frame to the mid-position when there is a mast.
- Depending on the number of part lines, rated lifting load is limited as follows:
1Part line...up to 13.5ton 2Part line...up to 25.0ton
3Part line...up to 37.5ton 4Part line...up to 50.0ton
5Part line...up to 62.5ton 6Part line...up to 75.0ton
7Part line...up to 87.5ton 8Part line...up to 100.0ton
9Part line...up to 112.5ton 10Part line...up to 125.0ton
11Part line...up to 137.5ton 12Part line...up to 150ton
- Always use a mast for boom length of 69m or over. Carefully follow the instruction manual concerning installation of pendant rope.
- Rated loads shown in bold lines are based on structural strength factors.



■ 1m Jib rated lifting loads (64ton counterweight)

(Unit: metric ton)

Boom length (m) \ Workingradius (m)	18.0	21.0	24.0	27.0	30.0	33.0	36.0	39.0	42.0	45.0	48.0	51.0	54.0	57.0	60.0
5.0	5.9m×13.5														
6.0	13.5	6.4m×13.5													
7.0	13.5	13.5	7.0m×13.5	7.5m×13.5											
8.0	13.5	13.5	13.5	13.5	8.0m×13.5	8.5m×13.5									
9.0	13.5	13.5	13.5	13.5	13.5	13.5	9.0m×13.5	9.6m×13.5							
10.0	13.5	13.5	13.5	13.5	13.5	13.5	13.5	13.5	10.1m×13.5	10.5m×13.5	11.1m×13.5	11.6m×13.5			
12.0	13.5	13.5	13.5	13.5	13.5	13.5	13.5	13.5	13.5	13.5	13.5	13.5	12.2m×13.5	12.7m×13.5	13.2m×13.5
14.0	13.5	13.5	13.5	13.5	13.5	13.5	13.5	13.5	13.5	13.5	13.5	13.5	13.5	13.5	13.5
16.0	13.5	13.5	13.5	13.5	13.5	13.5	13.5	13.5	13.5	13.5	13.5	13.5	13.5	13.5	13.5
18.0	13.5	13.5	13.5	13.5	13.5	13.5	13.5	13.5	13.5	13.5	13.5	13.5	13.5	13.5	13.5
20.0	18.8m×13.5	13.5	13.5	13.5	13.5	13.5	13.5	13.5	13.5	13.5	13.5	13.5	13.5	13.5	13.5
22.0		21.4m×13.5	13.5	13.5	13.5	13.5	13.5	13.5	13.5	13.5	13.5	13.5	13.5	13.5	13.5
24.0			24.0m×13.5	13.5	13.5	13.5	13.5	13.5	13.5	13.5	13.5	13.5	13.5	13.5	13.5
26.0				13.5	13.5	13.5	13.5	13.5	13.5	13.5	13.5	13.5	13.5	13.5	13.5
28.0				26.6m×13.5	13.5	13.5	13.5	13.5	13.5	13.5	13.5	13.5	13.5	13.5	13.5
30.0					29.2m×13.5	13.5	13.5	13.5	13.5	13.5	13.5	13.5	13.5	13.5	13.5
32.0						31.7m×13.5	13.5	13.5	13.5	13.5	13.5	13.5	13.5	13.5	13.5
34.0							13.5	13.5	13.5	13.5	13.4	13.3	13.1	12.9	12.7
36.0								34.3m×13.4	12.6	12.6	12.5	12.3	12.1	12.0	11.8
38.0									36.9m×12.1	11.5	11.4	11.2	11.0	10.9	10.7
40.0										39.5m×10.8	10.5	10.3	10.1	9.9	9.7
42.0											9.6	9.4	9.2	9.0	8.8
44.0											42.1m×9.6	8.7	8.5	8.3	8.1
46.0												44.7m×8.5	7.8	7.6	7.4
48.0													47.3m×7.4	6.9	6.6
50.0														49.9m×6.4	6.2
52.0															5.6
54.0															52.5m×5.5
56.0															55.1m×4.7

Boom length (m) \ Workingradius (m)	63.0	66.0	69.0	72.0	75.0	78.0	81.0
12.0	13.7m×13.5						
14.0	13.5	14.2m×13.5	14.8m×13.5	15.3m×13.5	15.8m×13.5		
16.0	13.5	13.5	13.5	13.5	13.5	16.3m×13.5	16.9m×13.5
18.0	13.5	13.5	13.5	13.5	13.5	13.5	13.5
20.0	13.5	13.5	13.5	13.5	13.5	13.5	13.5
22.0	13.5	13.5	13.5	13.5	13.5	13.5	13.5
24.0	13.5	13.5	13.5	13.5	13.5	13.5	13.5
26.0	13.5	13.5	13.5	13.5	13.5	13.5	13.5
28.0	13.5	13.5	13.5	13.5	13.5	13.5	13.5
30.0	13.5	13.5	13.5	13.5	13.5	13.5	13.5
32.0	13.5	13.5	13.5	13.5	13.3	13.1	12.9
34.0	12.6	12.4	12.2	12.1	11.9	11.7	11.6
36.0	11.4	11.3	11.1	10.9	10.7	10.5	10.3
38.0	10.3	10.1	9.9	9.8	9.6	9.4	9.3
40.0	9.3	9.1	8.9	8.8	8.6	8.4	8.3
42.0	8.5	8.3	8.1	7.9	7.8	7.6	7.5
44.0	7.7	7.5	7.3	7.1	7.0	6.8	6.7
46.0	7.0	6.8	6.6	6.4	6.3	6.1	6.0
48.0	6.4	6.2	6.0	5.8	5.7	5.5	5.3
50.0	5.8	5.6	5.4	5.2	5.1	4.9	4.7
52.0	5.3	5.1	4.9	4.7	4.5	4.3	4.1
54.0	4.8	4.6	4.4	4.2	4.0	3.8	3.5
56.0	4.4	4.2	4.0	3.8	3.6	3.3	3.1
58.0	57.7m×3.9	3.7	3.5	3.3	3.1	2.8	2.6
60.0		3.2	3.0	2.8	2.6	2.3	2.1
62.0		60.3m×3.1	2.6	2.4	2.2	2.0	1.8
64.0			62.9m×2.4	2.0	1.8	1.6	
66.0				65.5m×1.7			

Notes

- Above rated loads are based on the machine being operated on firm level ground, within 78° of tipping load at any point of 360° around the machine with forward stability factor of over 1.15.
- Working radius is horizontal distance from center of rotation to a vertical line through the center of gravity of the load.
- When the main hook block is installed, the lifting loads of jib must be reduced by the weight of hook block (main and jib) and other lifting devices.
 150ton hook block...2.40ton 100ton hook block...1.40ton
 60ton hook block...1.20ton 50ton hook block...1.00ton
 30ton hook block...1.00ton 13.5ton hook block...0.60ton
- Boom lengths for auxiliary jib attachment are 18.0m-81.0m.
- Always extend the "A" frame during operation.
- Use the 1 m auxiliary jib for crane operations only. Do not use for bucket operations.
- Rated loads for the 1 m auxiliary jib are based on structural strength.

Crane

CCH1500

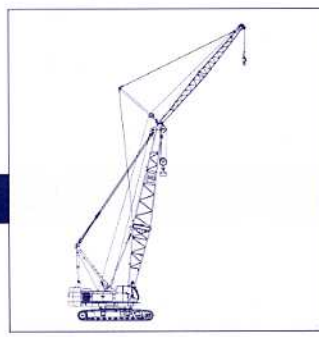

■ Aux. jib rated lifting loads (64 ton counterweight)

(Unit: metric ton)

Boom length (m)	45.0								48.0								51.0								
	13.0		19.0		25.0		31.0		13.0		19.0		25.0		31.0		13.0		19.0		25.0		31.0		
Jib length(m)	10°		30°		10°		30°		10°		30°		10°		30°		10°		30°		10°		30°		
Working radius (m)	10°	30°	10°	30°	10°	30°	10°	30°	10°	30°	10°	30°	10°	30°	10°	30°	10°	30°	10°	30°	10°	30°	10°	30°	
14.0	14.1m 13.5		15.5m 12.0						14.6m 13.5								15.1m 13.5								
16.0	13.5		12.0						13.5		16.0m 12.0						13.5		16.6m 12.0						
18.0	13.5	18.0m 13.0	12.0		18.2m 8.0		19.7m 3.5		13.5	18.5m 13.0	12.0		18.7m 8.0				13.5	19.0m 13.0	12.0		19.2m 8.0				
20.0	13.5	13.0	12.0	21.3m 8.0	8.0		3.5		13.5	13.0	12.0	21.8m 8.0	8.0		20.2m 3.5		13.5	13.0	12.0		8.0		20.7m 3.5		
22.0	13.5	13.0	12.0	8.0	8.0		3.5		13.5	13.0	12.0	8.0	8.0		3.5		13.5	13.0	12.0	22.4m 8.0	8.0			3.5	
24.0	13.5	13.0	12.0	8.0	8.0	25.7m 6.0	3.5		13.5	13.0	12.0	8.0	8.0		3.5		13.5	13.0	12.0	8.0	8.0			3.5	
26.0	13.5	13.0	12.0	8.0	8.0	6.0	3.5		13.5	13.0	12.0	8.0	8.0	26.2m 6.0	3.5		13.5	13.0	12.0	8.0	8.0	26.7m 6.0		3.5	
28.0	13.5	13.0	12.0	8.0	8.0	6.0	3.5	29.0m 3.0	13.5	13.0	12.0	8.0	8.0	6.0	3.5	29.6m 3.0	13.5	13.0	12.0	8.0	8.0	6.0	3.5		
30.0	13.5	13.0	12.0	8.0	8.0	6.0	3.5	3.0	13.5	13.0	12.0	8.0	8.0	6.0	3.5	3.0	13.5	13.0	12.0	8.0	8.0	6.0	3.5	30.1m 3.0	
32.0	13.5	13.0	12.0	8.0	8.0	6.0	3.5	3.0	13.5	13.0	12.0	8.0	8.0	6.0	3.5	3.0	13.5	13.0	12.0	8.0	8.0	6.0	3.5	3.0	
34.0	13.5	13.0	12.0	8.0	8.0	6.0	3.5	3.0	13.5	13.0	12.0	8.0	8.0	6.0	3.5	3.0	13.5	13.0	12.0	8.0	8.0	6.0	3.5	3.0	
36.0	13.3	13.0	12.0	8.0	8.0	6.0	3.5	3.0	13.1	13.0	12.0	8.0	8.0	6.0	3.5	3.0	12.9	12.9	12.0	8.0	8.0	6.0	3.5	3.0	
38.0	12.2	12.2	12.0	8.0	8.0	6.0	3.5	3.0	12.0	12.0	12.0	8.0	8.0	6.0	3.5	3.0	11.8	11.8	11.8	8.0	8.0	6.0	3.5	3.0	
40.0	11.3	11.3	11.3	8.0	8.0	6.0	3.5	3.0	11.1	11.1	11.1	8.0	8.0	6.0	3.5	3.0	10.9	10.9	10.9	8.0	8.0	6.0	3.5	3.0	
42.0	10.4	10.4	10.4	8.0	8.0	6.0	3.5	3.0	10.2	10.2	10.2	8.0	8.0	6.0	3.5	3.0	10.0	10.0	10.0	8.0	8.0	6.0	3.5	3.0	
44.0	9.7	9.7	9.7	8.0	8.0	6.0	3.5	3.0	9.5	9.5	9.5	8.0	8.0	6.0	3.5	3.0	9.3	9.3	9.3	8.0	8.0	6.0	3.5	3.0	
46.0	9.0	9.0	9.0	8.0	8.0	6.0	3.5	3.0	8.8	8.8	8.8	8.0	8.0	6.0	3.5	3.0	8.6	8.6	8.6	8.0	8.0	6.0	3.5	3.0	
48.0	8.3	8.3	8.3	8.0	8.0	6.0	3.5	3.0	8.1	8.1	8.1	8.0	8.0	6.0	3.5	3.0	7.9	7.9	7.9	7.9	7.9	6.0	3.5	3.0	
50.0	7.7	7.7	7.7	7.7	7.7	6.0	3.5	3.0	7.5	7.5	7.5	7.5	7.5	6.0	3.5	3.0	7.3	7.3	7.3	7.3	7.3	6.0	3.5	3.0	
52.0	7.2	7.2	7.2	7.2	7.2	6.0	3.5	3.0	7.0	7.0	7.0	7.0	7.0	6.0	3.5	3.0	6.8	6.8	6.8	6.8	6.8	6.0	3.5	3.0	
54.0	53.3m 6.9	6.7	6.7	6.7	6.7	6.0	3.5	3.0	6.5	6.5	6.5	6.5	6.5	6.0	3.5	3.0	6.3	6.3	6.3	6.3	6.3	6.0	3.5	3.0	
56.0		54.2m 6.7	6.3	6.3	6.3	6.0	3.5	3.0	55.9m 6.1	6.1	6.1	6.1	6.1	6.0	3.5	3.0	5.9	5.9	5.9	5.9	5.9	5.9	5.9	3.5	3.0
58.0			5.8	5.8	5.8	5.8	3.5	3.0		56.8m 5.9	5.6	5.6	5.6	5.6	3.5	3.0	5.4	5.4	5.4	5.4	5.4	5.4	5.4	3.5	3.0
60.0			58.8m 5.6	5.4	5.4	5.4	60.0m 3.5	60.0m 3.0			5.2	5.2	5.2	5.2	3.5	3.0	58.6m 5.3	59.4m 5.1	5.0	5.0	5.0	5.0	5.0	3.5	3.0
62.0				60.2m 5.4	5.0	5.0				61.4m 4.9	4.8	4.8	4.8	62.0m 3.5	62.0m 3.0			4.6	4.6	4.6	4.6	4.6	3.5	3.0	
64.0					64.0m 4.6	64.0m 4.6					62.8m 4.6	64.0m 4.4	64.0m 4.4					64.0m 4.2	4.2	4.2	4.2	4.2	64.0m 3.5	64.0m 3.0	
66.0																			65.4m 3.9	66.0m 3.8	66.0m 3.8				

Boom length (m)	54.0								57.0							
	13.0		19.0		25.0		31.0		13.0		19.0		25.0		31.0	
Jib length(m)	10°		30°		10°		30°		10°		30°		10°		30°	
Working radius (m)	10°	30°	10°	30°	10°	30°	10°	30°	10°	30°	10°	30°	10°	30°	10°	30°
14.0	15.6m 13.5															
16.0	13.5		17.1m 12.0						16.1m 13.5		17.6m 12.0					
18.0	13.5	19.5m 13.0	12.0		19.8m 8.0				13.5		12.0					
20.0	13.5	13.0	12.0		8.0		21.3m 3.5		13.5	20.0m 13.0	12.0		20.3m 8.0		21.8m 3.5	
22.0	13.5	13.0	12.0	22.9m 8.0	8.0		3.5		13.5	13.0	12.0	23.4m 8.0	8.0		3.5	
24.0	13.5	13.0	12.0	8.0	8.0		3.5		13.5	13.0	12.0	8.0	8.0		3.5	
26.0	13.5	13.0	12.0	8.0	8.0	27.2m 6.0	3.5		13.5	13.0	12.0	8.0	8.0	27.7m 6.0	3.5	
28.0	13.5	13.0	12.0	8.0	8.0	6.0	3.5		13.5	13.0	12.0	8.0	8.0	6.0	3.5	
30.0	13.5	13.0	12.0	8.0	8.0	6.0	3.5	30.6m 3.0	13.5	13.0	12.0	8.0	8.0	6.0	3.5	31.1m 3.0
32.0	13.5	13.0	12.0	8.0	8.0	6.0	3.5	3.0	13.5	13.0	12.0	8.0	8.0	6.0	3.5	3.0
34.0	13.5	13.0	12.0	8.0	8.0	6.0	3.5	3.0	13.5	13.0	12.0	8.0	8.0	6.0	3.5	3.0
36.0	12.8	12.8	12.0	8.0	8.0	6.0	3.5	3.0	12.6	12.6	12.0	8.0	8.0	6.0	3.5	3.0
38.0	11.7	11.7	11.7	8.0	8.0	6.0	3.5	3.0	11.5	11.5	11.5	8.0	8.0	6.0	3.5	3.0
40.0	10.7	10.7	10.7	8.0	8.0	6.0	3.5	3.0	10.5	10.5	10.5	8.0	8.0	6.0	3.5	3.0
42.0	9.8	9.8	9.8	8.0	8.0	6.0	3.5	3.0	9.6	9.6	9.6	8.0	8.0	6.0	3.5	3.0
44.0	9.1	9.1	9.1	8.0	8.0	6.0	3.5	3.0	8.9	8.9	8.9	8.0	8.0	6.0	3.5	3.0
46.0	8.4	8.4	8.4	8.0	8.0	6.0	3.5	3.0	8.2	8.2	8.2	8.0	8.0	6.0	3.5	3.0
48.0	7.7	7.7	7.7	7.7	7.7	6.0	3.5	3.0	7.6	7.6	7.6	7.6	7.6	6.0	3.5	3.0
50.0	7.1	7.1	7.1	7.1	7.1	6.0	3.5	3.0	7.0	7.0	7.0	7.0	7.0	6.0	3.5	3.0
52.0	6.6	6.6	6.6	6.6	6.6	6.0	3.5	3.0	6.4	6.4	6.4	6.4	6.4	6.0	3.5	3.0
54.0	6.1	6.1	6.1	6.1	6.1	6.0	3.5	3.0	5.9	5.9	5.9	5.9	5.9	5.9	3.5	3.0
56.0	5.7	5.7	5.7	5.7	5.7	5.7	3.5	3.0	5.5	5.5	5.5	5.5	5.5	5.5	3.5	3.0
58.0	5.2	5.2	5.2	5.2	5.2	5.2	3.5	3.0	5.0	5.0	5.0	5.0	5.0	5.0	3.5	3.0
60.0	4.8	4.8	4.8	4.8	4.8	4.8	3.5	3.0	4.6	4.6	4.6	4.6	4.6	4.6	3.5	3.0
62.0	61.1m 4.6	62.0m 4.4	4.4	4.4	4.4	4.4	3.5	3.0	4.2	4.2	4.2	4.2	4.2	4.2	3.5	3.0
64.0			4.0	4.0	4.0	4.0	3.5	3.0	63.7m 3.9	3.8	3.8	3.8	3.8	3.8	3.5	3.0
66.0			3.6	3.6	3.6	3.6	3.5	3.0		64.6m 3.7	3.4	3.4	3.4	3.4	3.4	3.0
68.0			66.6m 3.5	68.0m 3.2	3.2	3.2	3.2	3.0			3.0	3.0	3.0	3.0	3.0	3.0
70.0					2.9	2.9	2.9	2.9			69.2m 2.8	2.7	2.7	2.7	2.7	2.7
72.0					2.6	2.6	2.6	2.6				70.6m 2.6	2.4	2.4	2.4	2.4
74.0					72.4m 2.5	74.0m 2.3	2.3	2.3					2.1	2.1	2.1	2.1

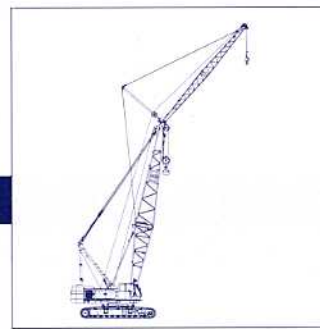

■Aux. jib rated lifting loads (64 ton counterweight)

(Unit: metric ton)

Boom length (m)	60.0								63.0								66.0							
	13.0		19.0		25.0		31.0		13.0		19.0		25.0		31.0		13.0		19.0		25.0		31.0	
Jib length(m)	10°		30°		10°		30°		10°		30°		10°		30°		10°		30°		10°		30°	
Offset angle	10°		30°		10°		30°		10°		30°		10°		30°		10°		30°		10°		30°	
Working radius (m)	16.7m 13.5								17.2m 13.5								17.7m 13.5							
	18.0		13.5		18.1m 12.0				13.5		18.7m 12.0						13.5		19.2m 12.0					
	20.0		13.5		20.6m 13.0		12.0		20.8m 8.0				22.3m 3.5		13.5		21.1m 13.0		12.0		21.3m 8.0		13.5	
	22.0		13.5		13.0		12.0		23.9m 8.0		8.0		22.3m 3.5		13.5		13.0		12.0		22.8m 3.5		13.5	
	24.0		13.5		13.0		12.0		8.0		8.0		3.5		13.5		13.0		12.0		24.4m 8.0		8.0	
	26.0		13.5		13.0		12.0		8.0		8.0		3.5		13.5		13.0		12.0		8.0		8.0	
	28.0		13.5		13.0		12.0		8.0		8.0		3.5		13.5		13.0		12.0		8.0		8.0	
	30.0		13.5		13.0		12.0		8.0		8.0		3.5		13.5		13.0		12.0		8.0		8.0	
	32.0		13.5		13.0		12.0		8.0		8.0		3.5		13.5		13.0		12.0		8.0		8.0	
	34.0		13.5		13.0		12.0		8.0		8.0		3.5		13.5		13.0		12.0		8.0		8.0	
	36.0		12.4		12.4		12.0		8.0		8.0		3.0		12.2		12.2		12.0		8.0		8.0	
	38.0		11.3		11.3		11.3		8.0		8.0		3.0		11.1		11.1		11.1		8.0		8.0	
	40.0		10.3		10.3		10.3		8.0		8.0		3.0		10.1		10.1		10.1		8.0		8.0	
	42.0		9.5		9.5		9.5		8.0		8.0		3.0		9.3		9.3		9.3		8.0		8.0	
	44.0		8.7		8.7		8.7		8.0		8.0		3.0		8.5		8.5		8.5		8.0		8.0	
	46.0		8.0		8.0		8.0		8.0		8.0		3.0		7.8		7.8		7.8		8.0		8.0	
	48.0		7.4		7.4		7.4		8.0		8.0		3.0		7.2		7.2		7.2		8.0		8.0	
	50.0		6.8		6.8		6.8		8.0		8.0		3.0		6.6		6.6		6.6		8.0		8.0	
	52.0		6.3		6.3		6.3		8.0		8.0		3.0		6.1		6.1		6.1		8.0		8.0	
	54.0		5.8		5.8		5.8		8.0		8.0		3.0		5.6		5.6		5.6		8.0		8.0	
	56.0		5.4		5.4		5.4		8.0		8.0		3.0		5.2		5.2		5.2		8.0		8.0	
	58.0		4.9		4.9		4.9		8.0		8.0		3.0		4.7		4.7		4.7		8.0		8.0	
	60.0		4.4		4.4		4.4		8.0		8.0		3.0		4.2		4.2		4.2		8.0		8.0	
	62.0		4.0		4.0		4.0		8.0		8.0		3.0		3.8		3.8		3.8		8.0		8.0	
	64.0		3.6		3.6		3.6		8.0		8.0		3.0		3.4		3.4		3.4		8.0		8.0	
	66.0		3.2		3.2		3.2		8.0		8.0		3.0		3.0		3.0		3.0		8.0		8.0	
	68.0		66.3m 3.1		67.2m 3.0		2.8		2.8		2.8		2.8		2.6		2.6		2.6		2.6		2.6	
	70.0						2.4		2.4		2.4		2.4		68.9m 2.4		69.8m 2.2		2.2		2.2		2.2	
	72.0				71.8m 2.2		2.1		2.1		2.1		2.1											
	74.0						73.2m 2.0																	

Boom length (m)	69.0								72.0							
	13.0		19.0		25.0		31.0		13.0		19.0		25.0		31.0	
Jib length(m)	10°		30°		10°		30°		10°		30°		10°		30°	
Offset angle	10°		30°		10°		30°		10°		30°		10°		30°	
Working radius (m)	18.0		18.2m 13.5		19.7m 12.0				16.7m 13.5							
	20.0		13.5		12.0				13.5		20.2m 12.0					
	22.0		13.5		22.1m 13.0		12.0		13.5		22.6m 13.0		12.0		22.9m 8.0	
	24.0		13.5		13.0		12.0		13.5		13.0		12.0		24.4m 3.5	
	26.0		13.5		13.0		12.0		13.5		13.0		12.0		26.0m 8.0	
	28.0		13.5		13.0		12.0		13.5		13.0		12.0		8.0	
	30.0		13.5		13.0		12.0		13.5		13.0		12.0		30.3m 6.0	
	32.0		13.5		13.0		12.0		13.5		13.0		12.0		33.7m 3.0	
	34.0		13.0		13.0		12.0		12.9		12.9		12.0		8.0	
	36.0		11.9		11.9		11.9		11.7		11.7		11.7		8.0	
	38.0		10.7		10.7		10.7		10.6		10.6		10.6		8.0	
	40.0		9.7		9.7		9.7		9.6		9.6		9.6		8.0	
	42.0		8.9		8.9		8.9		8.7		8.7		8.7		8.0	
	44.0		8.1		8.1		8.1		7.9		7.9		7.9		8.0	
	46.0		7.4		7.4		7.4		7.2		7.2		7.2		8.0	
	48.0		6.8		6.8		6.8		6.6		6.6		6.6		8.0	
	50.0		6.2		6.2		6.2		6.0		6.0		6.0		8.0	
	52.0		5.7		5.7		5.7		5.5		5.5		5.5		8.0	
	54.0		5.2		5.2		5.2		5.0		5.0		5.0		8.0	
	56.0		4.8		4.8		4.8		4.6		4.6		4.6		8.0	
	58.0		4.3		4.3		4.3		4.1		4.1		4.1		8.0	
	60.0		3.8		3.8		3.8		3.6		3.6		3.6		8.0	
	62.0		3.4		3.4		3.4		3.2		3.2		3.2		8.0	
	64.0		3.0		3.0		3.0		2.8		2.8		2.8		8.0	
	66.0		2.6		2.6		2.6		2.4		2.4		2.4		8.0	
	68.0		2.1		2.1		2.1		2.1		2.1		2.1		8.0	

Notes

- Above rated loads are based on the machine being operated on firm level ground, within 78% of tipping load at any point of 360° around the machine with forward stability factor of over 1.15.
- Working radius is horizontal distance from center of rotation to a vertical line through the center of gravity of the load.
- When the main hook block is installed, the lifting loads of jib must be reduced by the weight of hook block (main and jib) and other lifting devices.
150ton hook block...2.40ton
100ton hook block...1.40ton
60ton hook block...1.20ton
50ton hook block...1.00ton
30ton hook block...1.00ton
13.5ton hook block...0.60ton
- Always extend the "A" frame during operation.
- Use the auxiliary jibs for crane operations only. Do not use for bucket operations.
- Rated loads for auxiliary jib are based on structural strength.
- Boom lengths for auxiliary jib attachment are 45.0m - 72.0m.

Crane

(Additional counterweight, optional)

CCK1500



Main boom rated lifting loads (78ton counterweight, 16 ton weight for body)

(Unit: metric ton)

Boom length (m) / Working radius (m)	18.0	21.0	24.0	27.0	30.0	33.0	36.0	39.0	42.0	45.0	48.0	51.0	54.0	57.0	60.0
5.0	5.0m × 150.0	5.6m × 142.0													
6.0	146.1	142.0	6.1m × 134.0	6.6m × 125.0											
7.0	142.0	137.3	134.0	125.0	7.2m × 118.0	7.7m × 108.0									
8.0	115.0	114.5	114.0	113.5	113.0	108.0	8.2m × 98.0	8.7m × 92.0							
9.0	103.0	102.3	101.5	100.8	100.0	97.0	94.0	92.0	9.2m × 84.0	9.8m × 80.0					
10.0	96.0	95.5	95.0	94.5	94.0	91.4	88.8	86.2	83.6	80.0	10.3m × 77.0	10.8m × 73.0	11.3m × 68.0	11.9m × 62.0	
12.0	74.0	73.9	73.8	73.6	73.5	73.2	72.9	72.6	72.3	72.0	69.5	67.1	64.6	62.0	12.4m × 60.0
14.0	62.0	61.8	61.5	61.3	61.0	60.8	60.6	60.3	60.1	59.9	58.9	57.9	57.0	56.0	55.0
16.0	51.0	50.9	50.8	50.6	50.5	50.4	50.3	50.2	50.1	50.0	49.8	49.6	49.4	49.2	49.0
18.0	17.2m × 46.4	43.3	43.2	43.0	42.9	42.8	42.7	42.7	42.6	42.5	42.4	42.3	42.2	42.1	42.0
20.0		19.8m × 38.4	37.8	37.6	37.5	37.4	37.3	37.1	37.0	36.9	36.8	36.7	36.6	36.5	36.4
22.0			33.4	33.1	32.7	32.6	32.5	32.4	32.3	32.2	32.1	32.0	31.8	31.7	31.6
24.0			22.4m × 32.7	29.5	29.2	29.1	29.0	28.9	28.8	28.7	28.6	28.5	28.3	28.2	28.1
26.0				25.0m × 28.0	26.4	26.3	26.2	26.0	25.9	25.8	25.7	25.5	25.4	25.2	25.1
28.0					27.6m × 24.5	23.9	23.7	23.6	23.4	23.3	23.1	23.0	22.8	22.7	22.5
30.0						21.8	21.7	21.5	21.4	21.2	21.0	20.9	20.7	20.6	20.4
32.0						30.2m × 21.7	19.9	19.7	19.6	19.5	19.3	19.1	19.0	18.8	18.6
34.0							32.8m × 19.2	18.1	18.0	17.9	17.7	17.5	17.4	17.2	17.0
36.0								35.4m × 17.1	16.6	16.5	16.3	16.1	16.0	15.8	15.6
38.0									38.0m × 15.4	15.3	15.1	14.9	14.7	14.5	14.3
40.0										14.3	14.1	13.9	13.6	13.4	13.2
42.0										40.6m × 14.0	13.1	12.9	12.6	12.4	12.2
44.0											43.2m × 12.5	11.9	11.7	11.5	11.3
46.0												45.8m × 11.2	10.9	10.7	10.5
48.0													10.2	10.0	9.8
50.0													48.4m × 10.0	9.3	9.1
52.0														51.0m × 8.9	8.4
54.0															53.6m × 8.0

Boom length (m) / Working radius (m)	63.0	66.0	69.0	72.0	75.0	78.0	81.0	84.0
12.0	12.9m × 54.0	13.4m × 48.0	13.9m × 44.0					
14.0	51.3	48.0	44.0	14.5m × 39.0	15.0m × 34.5	15.5m × 31.0		
16.0	46.5	44.0	43.2	39.0	34.5	31.0	16.0m × 27.5	16.5m × 24.0
18.0	41.1	40.1	40.0	37.2	34.3	31.0	27.5	24.0
20.0	36.2	35.9	35.7	33.6	31.5	29.4	27.5	24.0
22.0	31.5	31.4	31.3	30.0	28.7	27.4	26.1	24.0
24.0	28.0	27.8	27.7	27.0	26.4	25.7	25.0	22.0
26.0	25.0	24.8	24.5	24.3	24.0	23.8	23.5	20.6
28.0	22.4	22.2	22.0	21.9	21.8	21.6	21.5	19.3
30.0	20.3	20.1	19.9	19.8	19.7	19.6	19.5	18.0
32.0	18.4	18.2	18.0	17.9	17.8	17.7	17.6	17.1
34.0	16.8	16.6	16.4	16.3	16.2	16.1	16.0	15.8
36.0	15.4	15.2	15.0	14.9	14.8	14.6	14.5	14.3
38.0	14.1	13.9	13.7	13.6	13.5	13.4	13.3	13.0
40.0	13.0	12.8	12.6	12.5	12.4	12.3	12.2	11.9
42.0	12.0	11.8	11.6	11.5	11.4	11.3	11.2	10.8
44.0	11.1	10.9	10.7	10.6	10.5	10.4	10.3	9.8
46.0	10.3	10.1	9.9	9.8	9.7	9.5	9.4	8.9
48.0	9.6	9.4	9.1	8.9	8.8	8.6	8.4	8.0
50.0	8.9	8.7	8.5	8.4	8.2	8.1	7.9	7.4
52.0	8.3	8.1	7.8	7.7	7.5	7.4	7.2	6.8
54.0	7.7	7.5	7.3	7.2	7.0	6.9	6.7	6.2
56.0	7.2	7.0	6.8	6.6	6.5	6.3	6.1	5.7
58.0	56.2m × 7.1	6.5	6.3	6.1	6.0	5.8	5.6	5.2
60.0		58.8m × 6.3	5.8	5.6	5.5	5.3	5.1	4.7
62.0			61.4m × 5.5	5.2	5.0	4.8	4.6	4.3
64.0				64.0m × 4.8	4.6	4.4	4.2	3.8
66.0					4.2	4.0	3.8	3.4

Notes

- Above rated loads are based on the machine being operated on firm level ground, within 78% of tipping load at any point of 360° around the machine with forward stability factor of over 1.15.
- Working radius is horizontal distance from center of rotation to a vertical line through the center of gravity of the load.
- The weight of the slings, hook block(s) and auxiliary lifting devices must be considered to be a part of the load.
Hook block weight:
150ton hook block...2.40ton 100ton hook block...1.40ton
60ton hook block...1.20ton 50ton hook block...1.00ton
30ton hook block...1.00ton 13.5ton hook block...0.60ton
- Jib boom can be fitted to main boom in the following combinations.

Jib length(m)	Auxiliary	13.0	19.0	25.0	31.0
Boom length(m)	18.0~81.0	45.0~72.0	45.0~72.0	45.0~72.0	45.0~72.0

- When jib boom is fitted actual loads that can be lifted with main hook block should be reduced according to the below table (the weights include auxiliary hook block).

Jib length(m)	Auxiliary	13.0	19.0	25.0	31.0
Weight to be deducted(ton)	0.80	3.5	4.0	4.9	6.0

- High "A" Frame should be extended before working.
Extend the "A" frame to the highest position when there is no mast.
Extend the "A" frame to the mid-position when there is a mast.
- Depending on the number of part lines, rated lifting load is limited as follows:
1Part line...up to 13.5ton 2Part line...up to 25.0ton
3Part line...up to 37.5ton 4Part line...up to 50.0ton
5Part line...up to 62.5ton 6Part line...up to 75.0ton
7Part line...up to 87.5ton 8Part line...up to 100.0ton
9Part line...up to 112.5ton 10Part line...up to 125.0ton
11Part line...up to 137.5ton 12Part line...up to 150ton
- Always use a mast for boom length of 69m or over. Carefully follow the instruction manual concerning installation of pendant rope.
- Rated loads shown in bold lines are based on structural strength factors.

Crane

(Additional counterweight, optional)

CCH1500



■ 1m aux. jib rated lifting loads (78ton counterweight, 16 ton weight for body)

(Unit: metric ton)

Boom length (m) / Working radius (m)	18.0	21.0	24.0	27.0	30.0	33.0	36.0	39.0	42.0	45.0	48.0	51.0	54.0	57.0	60.0
5.0	5.9m ^x _{13.5}														
6.0	13.5	6.4m ^x _{13.5}													
7.0	13.5	13.5	7.0m ^x _{13.5}	7.5m ^x _{13.5}											
8.0	13.5	13.5	13.5	13.5	8.0m ^x _{13.5}	8.5m ^x _{13.5}									
9.0	13.5	13.5	13.5	13.5	13.5	13.5	9.0m ^x _{13.5}	9.6m ^x _{13.5}							
10.0	13.5	13.5	13.5	13.5	13.5	13.5	13.5	13.5	10.1m ^x _{13.5}	10.5m ^x _{13.5}	11.1m ^x _{13.5}	11.6m ^x _{13.5}			
12.0	13.5	13.5	13.5	13.5	13.5	13.5	13.5	13.5	13.5	13.5	13.5	13.5	12.2m ^x _{13.5}	12.7m ^x _{13.5}	13.2m ^x _{13.5}
14.0	13.5	13.5	13.5	13.5	13.5	13.5	13.5	13.5	13.5	13.5	13.5	13.5	13.5	13.5	13.5
16.0	13.5	13.5	13.5	13.5	13.5	13.5	13.5	13.5	13.5	13.5	13.5	13.5	13.5	13.5	13.5
18.0	13.5	13.5	13.5	13.5	13.5	13.5	13.5	13.5	13.5	13.5	13.5	13.5	13.5	13.5	13.5
20.0	18.8m ^x _{13.5}	13.5	13.5	13.5	13.5	13.5	13.5	13.5	13.5	13.5	13.5	13.5	13.5	13.5	13.5
22.0		21.4m ^x _{13.5}	13.5	13.5	13.5	13.5	13.5	13.5	13.5	13.5	13.5	13.5	13.5	13.5	13.5
24.0			24.0m ^x _{13.5}	13.5	13.5	13.5	13.5	13.5	13.5	13.5	13.5	13.5	13.5	13.5	13.5
26.0				13.5	13.5	13.5	13.5	13.5	13.5	13.5	13.5	13.5	13.5	13.5	13.5
28.0				26.6m ^x _{13.5}	13.5	13.5	13.5	13.5	13.5	13.5	13.5	13.5	13.5	13.5	13.5
30.0					29.2m ^x _{13.5}	13.5	13.5	13.5	13.5	13.5	13.5	13.5	13.5	13.5	13.5
32.0						31.7m ^x _{13.5}	13.5	13.5	13.5	13.5	13.5	13.5	13.5	13.5	13.5
34.0							13.5	13.5	13.5	13.5	13.5	13.5	13.5	13.5	13.5
36.0							34.3m ^x _{13.5}	13.5	13.5	13.5	13.5	13.5	13.5	13.5	13.5
38.0								36.9m ^x _{13.5}	13.5	13.5	13.5	13.5	13.5	13.5	13.5
40.0									39.5m ^x _{13.5}	13.5	13.3	13.1	12.8	12.6	12.4
42.0										12.5	12.3	12.1	11.8	11.6	11.4
44.0										42.1m ^x _{12.5}	11.3	11.1	10.9	10.7	10.5
46.0											44.7m ^x _{11.0}	10.3	10.1	9.9	9.7
48.0												47.3m ^x _{9.8}	9.4	9.2	9.0
50.0													49.9m ^x _{8.7}	8.5	8.3
52.0														7.8	7.6
54.0														52.5m ^x _{7.7}	7.0
56.0															55.1m ^x _{6.8}

Boom length (m) / Working radius (m)	63.0	66.0	69.0	72.0	75.0	78.0	81.0
12.0	13.7m ^x _{13.5}						
14.0	13.5	14.2m ^x _{13.5}	14.8m ^x _{13.5}	15.3m ^x _{13.5}	15.8m ^x _{13.5}		
16.0	13.5	13.5	13.5	13.5	13.5	16.3m ^x _{13.5}	16.9m ^x _{13.5}
18.0	13.5	13.5	13.5	13.5	13.5	13.5	13.5
20.0	13.5	13.5	13.5	13.5	13.5	13.5	13.5
22.0	13.5	13.5	13.5	13.5	13.5	13.5	13.5
24.0	13.5	13.5	13.5	13.5	13.5	13.5	13.5
26.0	13.5	13.5	13.5	13.5	13.5	13.5	13.5
28.0	13.5	13.5	13.5	13.5	13.5	13.5	13.5
30.0	13.5	13.5	13.5	13.5	13.5	13.5	13.5
32.0	13.5	13.5	13.5	13.5	13.5	13.5	13.5
34.0	13.5	13.5	13.5	13.5	13.5	13.5	13.5
36.0	13.5	13.5	13.5	13.5	13.5	13.5	13.5
38.0	13.3	13.1	12.9	12.8	12.7	12.6	12.5
40.0	12.2	12.0	11.8	11.7	11.6	11.5	11.4
42.0	11.2	11.0	10.8	10.7	10.6	10.5	10.4
44.0	10.3	10.1	9.9	9.8	9.7	9.6	9.5
46.0	9.5	9.3	9.1	9.0	8.9	8.7	8.6
48.0	8.8	8.6	8.3	8.1	8.0	7.8	7.6
50.0	8.1	7.9	7.7	7.6	7.4	7.3	7.1
52.0	7.5	7.3	7.0	6.9	6.7	6.6	6.4
54.0	6.9	6.7	6.5	6.4	6.2	6.1	5.9
56.0	6.4	6.2	6.0	5.8	5.7	5.5	5.3
58.0	57.7m ^x _{5.9}	5.7	5.5	5.3	5.2	5.0	4.8
60.0		5.1	5.0	4.8	4.7	4.5	4.3
62.0		60.3m ^x _{5.0}	4.6	4.4	4.2	4.0	3.8
64.0			62.9m ^x _{4.4}	4.0	3.8	3.6	3.4
66.0				65.5m ^x _{3.6}	3.4	3.2	3.0

Notes

- Above rated loads are based on the machine being operated on firm level ground, within 78% of tipping load at any point of 360° around the machine with forward stability factor of over 1.15.
- Working radius is horizontal distance from center of rotation to a vertical line through the center of gravity of the load.
- When the main hook block is installed, the lifting loads of jib must be reduced by the weight of hook block (main and jib) and other lifting devices.
 150ton hook block...2.40ton 100ton hook block...1.40ton
 60ton hook block...1.20ton 50ton hook block...1.00ton
 30ton hook block...1.00ton 13.5ton hook block...0.60ton
- Boom lengths for auxiliary jib attachment are 18.0m-81.0m.
- Always extend the "A" frame during operation.
- Use the 1 m auxiliary jib for crane operations only. Do not use for bucket operations.
- Rated loads for the 1 m auxiliary jib are based on structural strength.

Crane

(Additional counterweight, optional)

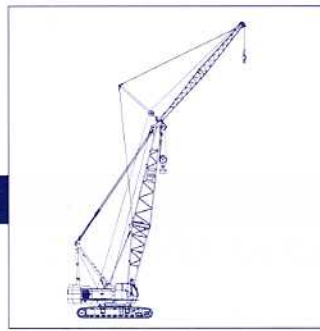

CCH1500

■ Aux. jib rated lifting loads (78ton counterweight, 16 ton weight for body)

(Unit : metric ton)

Boom length (m)	45.0								48.0								51.0								
	13.0		19.0		25.0		31.0		13.0		19.0		25.0		31.0		13.0		19.0		25.0		31.0		
	Offset angle		Offset angle		Offset angle		Offset angle		Offset angle		Offset angle		Offset angle		Offset angle		Offset angle		Offset angle		Offset angle		Offset angle		
Working radius (m)	10°	30°	10°	30°	10°	30°	10°	30°	10°	30°	10°	30°	10°	30°	10°	30°	10°	30°	10°	30°	10°	30°	10°	30°	
14.0	14.1m 13.5		15.5m 12.0						14.6m 13.5								15.1m 13.5								
16.0	13.5		12.0						13.5		16m 12.0						13.5		16.6m 12.0						
18.0	13.5	18m 13.0	12.0		18.2m 8.0		19.7m 3.5		13.5	18.5m 13.0	12.0		18.7m 8.0			13.5	19m 13.0	12.0		19.2m 8.0					
20.0	13.5	13.0	12.0	21.3m 8.0	8.0		3.5		13.5	13.0	12.0	21.8m 8.0	8.0		20.2m 3.5	13.5	13.0	12.0		8.0		20.7m 3.5			
22.0	13.5	13.0	12.0	8.0	8.0		3.5		13.5	13.0	12.0	8.0	8.0		3.5	13.5	13.0	12.0	22.4m 8.0	8.0			20.7m 3.5		
24.0	13.5	13.0	12.0	8.0	8.0	25.7m 6.0	3.5		13.5	13.0	12.0	8.0	8.0		3.5	13.5	13.0	12.0	8.0	8.0			20.7m 3.5		
26.0	13.5	13.0	12.0	8.0	8.0	6.0	3.5		13.5	13.0	12.0	8.0	8.0	26.2m 6.0	3.5	13.5	13.0	12.0	8.0	8.0	26.7m 6.0	3.5			
28.0	13.5	13.0	12.0	8.0	8.0	6.0	3.5	29m 3.0	13.5	13.0	12.0	8.0	8.0	6.0	3.5	29.6m 3.0	13.5	13.0	12.0	8.0	8.0	6.0	3.5		
30.0	13.5	13.0	12.0	8.0	8.0	6.0	3.5	3.0	13.5	13.0	12.0	8.0	8.0	6.0	3.5	3.0	13.5	13.0	12.0	8.0	8.0	6.0	3.5	30.1m 3.0	
32.0	13.5	13.0	12.0	8.0	8.0	6.0	3.5	3.0	13.5	13.0	12.0	8.0	8.0	6.0	3.5	3.0	13.5	13.0	12.0	8.0	8.0	6.0	3.5	3.0	
34.0	13.5	13.0	12.0	8.0	8.0	6.0	3.5	3.0	13.5	13.0	12.0	8.0	8.0	6.0	3.5	3.0	13.5	13.0	12.0	8.0	8.0	6.0	3.5	3.0	
36.0	13.5	13.0	12.0	8.0	8.0	6.0	3.5	3.0	13.5	13.0	12.0	8.0	8.0	6.0	3.5	3.0	13.5	13.0	12.0	8.0	8.0	6.0	3.5	3.0	
38.0	13.5	13.0	12.0	8.0	8.0	6.0	3.5	3.0	13.5	13.0	12.0	8.0	8.0	6.0	3.5	3.0	13.5	13.0	12.0	8.0	8.0	6.0	3.5	3.0	
40.0	13.5	13.0	12.0	8.0	8.0	6.0	3.5	3.0	13.5	13.0	12.0	8.0	8.0	6.0	3.5	3.0	13.5	13.0	12.0	8.0	8.0	6.0	3.5	3.0	
42.0	13.3	13.0	12.0	8.0	8.0	6.0	3.5	3.0	13.1	13.0	12.0	8.0	8.0	6.0	3.5	3.0	12.9	12.9	12.0	8.0	8.0	6.0	3.5	3.0	
44.0	12.3	12.3	12.0	8.0	8.0	6.0	3.5	3.0	12.1	12.1	12.0	8.0	8.0	6.0	3.5	3.0	11.9	11.9	11.9	8.0	8.0	6.0	3.5	3.0	
46.0	11.5	11.5	11.5	8.0	8.0	6.0	3.5	3.0	11.3	11.3	11.3	8.0	8.0	6.0	3.5	3.0	11.1	11.1	11.1	8.0	8.0	6.0	3.5	3.0	
48.0	10.7	10.7	10.7	8.0	8.0	6.0	3.5	3.0	10.5	10.5	10.5	8.0	8.0	6.0	3.5	3.0	10.3	10.3	10.3	8.0	8.0	6.0	3.5	3.0	
50.0	10.0	10.0	10.0	8.0	8.0	6.0	3.5	3.0	9.8	9.8	9.8	8.0	8.0	6.0	3.5	3.0	9.6	9.6	9.6	8.0	8.0	6.0	3.5	3.0	
52.0	9.3	9.3	9.3	8.0	8.0	6.0	3.5	3.0	9.1	9.1	9.1	8.0	8.0	6.0	3.5	3.0	9.0	9.0	9.0	8.0	8.0	6.0	3.5	3.0	
54.0	53.3m 8.9	8.7	8.7	8.0	8.0	6.0	3.5	3.0	8.5	8.5	8.5	8.0	8.0	6.0	3.5	3.0	8.4	8.4	8.4	8.0	8.0	6.0	3.5	3.0	
56.0		54.2m 8.7	8.2	8.0	8.0	6.0	3.5	3.0	55.9m 8.1	8.0	8.0	8.0	8.0	6.0	3.5	3.0	7.9	7.9	7.9	7.9	7.9	6.0	3.5	3.0	
58.0			7.7	7.7	7.7	6.0	3.5	3.0	56.8m 7.8	7.5	7.5	7.5	6.0	3.5	3.0	7.4	7.4	7.4	7.4	7.4	6.0	3.5	3.0		
60.0			58.8m 7.5	7.2	7.2	6.0	3.5	3.0	60m 3.5	60m 3.0		7.0	7.0	7.0	6.0	3.5	3.0	58.5m 7.2	59.4m 7.0	6.8	6.8	6.8	6.0	3.5	3.0
62.0				60.2m 7.2	6.7	6.0					61.4m 6.7	6.5	6.5	6.0	6.0	3.5	3.0	62m 3.5	62m 3.0	6.3	6.3	6.3	6.0	3.5	3.0
64.0					64m 6.3	64m 6.0						62.8m 6.3	64m 6.1	64m 6.0						64m 5.9	5.9	5.9	5.9	64m 3.5	64m 3.0
66.0																				65.4m 5.6	66m 5.5	66m 5.5			

Boom length (m)	54.0								57.0							
	13.0		19.0		25.0		31.0		13.0		19.0		25.0		31.0	
	Offset angle		Offset angle		Offset angle		Offset angle		Offset angle		Offset angle		Offset angle		Offset angle	
Working radius (m)	10°	30°	10°	30°	10°	30°	10°	30°	10°	30°	10°	30°	10°	30°	10°	30°
14.0	15.6m 13.5															
16.0	13.5		17.1m 12.0						16.1m 13.5		17.6m 12.0					
18.0	13.5	19.5m 13.0	12.0		19.8m 8.0				13.5		12.0					
20.0	13.5	13.0	12.0		8.0		21.3m 3.5		13.5	20m 13.0	12.0		20.3m 8.0		21.8m 3.5	
22.0	13.5	13.0	12.0	22.9m 8.0	8.0		3.5		13.5	13.0	12.0	23.4m 8.0	8.0		3.5	
24.0	13.5	13.0	12.0	8.0	8.0		3.5		13.5	13.0	12.0	8.0	8.0		3.5	
26.0	13.5	13.0	12.0	8.0	8.0	27.2m 6.0	3.5		13.5	13.0	12.0	8.0	8.0	27.7m 6.0	3.5	
28.0	13.5	13.0	12.0	8.0	8.0	6.0	3.5		13.5	13.0	12.0	8.0	8.0	6.0	3.5	
30.0	13.5	13.0	12.0	8.0	8.0	6.0	3.5	30.6m 3.0	13.5	13.0	12.0	8.0	8.0	6.0	3.5	31.1m 3.0
32.0	13.5	13.0	12.0	8.0	8.0	6.0	3.5	3.0	13.5	13.0	12.0	8.0	8.0	6.0	3.5	3.0
34.0	13.5	13.0	12.0	8.0	8.0	6.0	3.5	3.0	13.5	13.0	12.0	8.0	8.0	6.0	3.5	3.0
36.0	13.5	13.0	12.0	8.0	8.0	6.0	3.5	3.0	13.5	13.0	12.0	8.0	8.0	6.0	3.5	3.0
38.0	13.5	13.0	12.0	8.0	8.0	6.0	3.5	3.0	13.5	13.0	12.0	8.0	8.0	6.0	3.5	3.0
40.0	13.5	13.0	12.0	8.0	8.0	6.0	3.5	3.0	13.4	13.0	12.0	8.0	8.0	6.0	3.5	3.0
42.0	12.6	12.6	12.0	8.0	8.0	6.0	3.5	3.0	12.4	12.4	12.0	8.0	8.0	6.0	3.5	3.0
44.0	11.7	11.7	11.7	8.0	8.0	6.0	3.5	3.0	11.5	11.5	11.5	8.0	8.0	6.0	3.5	3.0
46.0	10.9	10.9	10.9	8.0	8.0	6.0	3.5	3.0	10.7	10.7	10.7	8.0	8.0	6.0	3.5	3.0
48.0	10.2	10.2	10.2	8.0	8.0	6.0	3.5	3.0	10.0	10.0	10.0	8.0	8.0	6.0	3.5	3.0
50.0	9.5	9.5	9.5	8.0	8.0	6.0	3.5	3.0	9.3	9.3	9.3	8.0	8.0	6.0	3.5	3.0
52.0	8.8	8.8	8.8	8.0	8.0	6.0	3.5	3.0	8.6	8.6	8.6	8.0	8.0	6.0	3.5	3.0
54.0	8.2	8.2	8.2	8.0	8.0	6.0	3.5	3.0	8.0	8.0	8.0	8.0	8.0	6.0	3.5	3.0
56.0	7.7	7.7	7.7	7.7	7.7	6.0	3.5	3.0	7.5	7.5	7.5	7.5	7.5	6.0	3.5	3.0
58.0	7.2	7.2	7.2	7.2	7.2	6.0	3.5	3.0	7.0	7.0	7.0	7.0	7.0	6.0	3.5	3.0
60.0	6.6	6.6	6.6	6.6	6.6	6.0	3.5	3.0	6.5	6.5	6.5	6.5	6.5	6.0	3.5	3.0
62.0	61.1m 6.4	62m 6.1	6.1	6.1	6.1	6.0	3.5	3.0	6.0	6.0	6.0	6.0	6.0	6.0	3.5	3.0
64.0			5.7	5.7	5.7	5.7	3.5	3.0	63.7m 5.6	5.5	5.5	5.5	5.5	5.5	3.5	3.0
66.0			5.3	5.3	5.3	5.3	66m 3.5	66m 3.0	64.6m 5.4	5.0	5.0	5.0	5.0	5.0	66m 3.5	66m 3.0
68.0			66.6m 5.1	68m 4.9	68m 4.9	68m 4.9				4.6	4.6	4.6	4.6			
70.0										69.2m 4.4	4.3	70m 4.3	70m 4.3			
72.0											70.6m 4.2					

Crane

(Additional counterweight, optional)

CCH1500

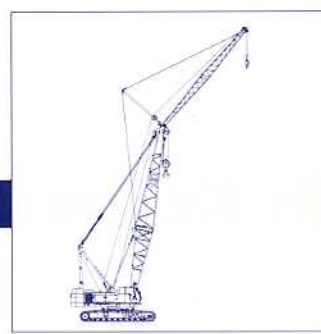

■ Aux. jib rated lifting loads (78ton counterweight, 16 ton weight for body)

(Unit : metric ton)

Boom length (m)	60.0								63.0								66.0								
Jib length (m)	13.0		19.0		25.0		31.0		13.0		19.0		25.0		31.0		13.0		19.0		25.0		31.0		
Offset angle	10°	30°	10°	30°	10°	30°	10°	30°	10°	30°	10°	30°	10°	30°	10°	30°	10°	30°	10°	30°	10°	30°	10°	30°	
Working radius (m)																									
16.0	16.7m ^x _{13.5}								17.2m ^x _{13.5}									17.7m ^x _{13.5}							
18.0	13.5		18.1m ^x _{12.0}						13.5				18.7m ^x _{12.0}					13.5							
20.0	13.5	20.6m ^x _{13.0}	12.0						13.5	21.1m ^x _{13.0}	12.0			21.3m ^x _{8.0}				13.5	21.6m ^x _{13.0}	12.0			21.8m ^x _{8.0}		
22.0	13.5	13.0	12.0	8.0		20.8m ^x _{8.0}	8.0		22.3m ^x _{3.5}	13.5	13.0	12.0		8.0				22.8m ^x _{3.5}	13.5	13.0	12.0			23.3m ^x _{3.5}	
24.0	13.5	13.0	12.0	8.0	8.0				3.5	13.5	13.0	12.0		24.4m ^x _{8.0}	8.0			3.5	13.5	13.0	12.0		25m ^x _{8.0}	8.0	3.5
26.0	13.5	13.0	12.0	8.0	8.0				3.5	13.5	13.0	12.0	8.0	8.0				3.5	13.5	13.0	12.0	8.0	8.0		3.5
28.0	13.5	13.0	12.0	8.0	8.0	28.3m ^x _{6.0}	3.5			13.5	13.0	12.0	8.0	8.0	28.8m ^x _{6.0}	3.5			13.5	13.0	12.0	8.0	8.0	29.3m ^x _{6.0}	3.5
30.0	13.5	13.0	12.0	8.0	8.0	6.0	3.5	31.7m ^x _{3.0}		13.5	13.0	12.0	8.0	8.0	6.0	3.5			13.5	13.0	12.0	8.0	8.0	6.0	3.5
32.0	13.5	13.0	12.0	8.0	8.0	6.0	3.5	3.0		13.5	13.0	12.0	8.0	8.0	6.0	3.5	32.2m ^x _{3.0}		13.5	13.0	12.0	8.0	8.0	6.0	3.5
34.0	13.5	13.0	12.0	8.0	8.0	6.0	3.5	3.0		13.5	13.0	12.0	8.0	8.0	6.0	3.5	3.0		13.5	13.0	12.0	8.0	8.0	6.0	3.5
36.0	13.5	13.0	12.0	8.0	8.0	6.0	3.5	3.0		13.5	13.0	12.0	8.0	8.0	6.0	3.5	3.0		13.5	13.0	12.0	8.0	8.0	6.0	3.5
38.0	13.5	13.0	12.0	8.0	8.0	6.0	3.5	3.0		13.5	13.0	12.0	8.0	8.0	6.0	3.5	3.0		13.5	13.0	12.0	8.0	8.0	6.0	3.5
40.0	13.2	13.0	12.0	8.0	8.0	6.0	3.5	3.0		13.0	13.0	12.0	8.0	8.0	6.0	3.5	3.0		12.8	12.8	12.0	8.0	8.0	6.0	3.5
42.0	12.2	12.2	12.0	8.0	8.0	6.0	3.5	3.0		12.0	12.0	12.0	8.0	8.0	6.0	3.5	3.0		11.8	11.8	11.8	8.0	8.0	6.0	3.5
44.0	11.3	11.3	11.3	8.0	8.0	6.0	3.5	3.0		11.1	11.1	11.1	8.0	8.0	6.0	3.5	3.0		10.9	10.9	10.9	8.0	8.0	6.0	3.5
46.0	10.5	10.5	10.5	8.0	8.0	6.0	3.5	3.0		10.3	10.3	10.3	8.0	8.0	6.0	3.5	3.0		10.1	10.1	10.1	8.0	8.0	6.0	3.5
48.0	9.8	9.8	9.8	8.0	8.0	6.0	3.5	3.0		9.6	9.6	9.6	8.0	8.0	6.0	3.5	3.0		9.4	9.4	9.4	8.0	8.0	6.0	3.5
50.0	9.1	9.1	9.1	8.0	8.0	6.0	3.5	3.0		8.9	8.9	8.9	8.0	8.0	6.0	3.5	3.0		8.7	8.7	8.7	8.0	8.0	6.0	3.5
52.0	8.4	8.4	8.4	8.0	8.0	6.0	3.5	3.0		8.3	8.3	8.3	8.0	8.0	6.0	3.5	3.0		8.1	8.1	8.1	8.0	8.0	6.0	3.5
54.0	7.8	7.8	7.8	7.8	7.8	6.0	3.5	3.0		7.7	7.7	7.7	7.7	7.7	6.0	3.5	3.0		7.5	7.5	7.5	7.5	7.5	6.0	3.5
56.0	7.3	7.3	7.3	7.3	7.3	6.0	3.5	3.0		7.2	7.2	7.2	7.2	7.2	6.0	3.5	3.0		7.0	7.0	7.0	7.0	7.0	6.0	3.5
58.0	6.8	6.8	6.8	6.8	6.8	6.0	3.5	3.0		6.7	6.7	6.7	6.7	6.7	6.0	3.5	3.0		6.5	6.5	6.5	6.5	6.5	6.0	3.5
60.0	6.3	6.3	6.3	6.3	6.3	6.0	3.5	3.0		6.1	6.1	6.1	6.1	6.1	6.0	3.5	3.0		5.9	5.9	5.9	5.9	5.9	5.9	3.5
62.0	5.8	5.8	5.8	5.8	5.8	5.8	3.5	3.0		5.6	5.6	5.6	5.6	5.6	5.6	3.5	3.0		5.4	5.4	5.4	5.4	5.4	5.4	3.5
64.0	5.3	5.3	5.3	5.3	5.3	5.3	3.5	3.0		5.1	5.1	5.1	5.1	5.1	5.1	3.5	3.0		4.9	4.9	4.9	4.9	4.9	4.9	3.5
66.0	4.8	4.8	4.8	4.8	4.8	4.8	3.5	3.0		4.6	4.6	4.6	4.6	4.6	4.6	3.5	3.0		4.4	4.4	4.4	4.4	4.4	4.4	3.5
68.0	4.4	4.4	4.4	4.4	4.4	4.4	3.5	3.0		4.2	4.2	4.2	4.2	4.2	4.2	3.5	3.0		4.0	4.0	4.0	4.0	4.0	4.0	3.5
70.0	4.1	4.1	4.1	4.1	4.1	4.1	3.5	3.0		4.0	4.0	4.0	4.0	4.0	4.0	3.5	3.0		3.6	3.6	3.6	3.6	3.6	3.6	3.5
72.0	3.7	3.7	3.7	3.7	3.7	3.7	3.5	3.0		3.5	3.5	3.5	3.5	3.5	3.5	3.5	3.0		3.3	3.3	3.3	3.3	3.3	3.3	3.0
74.0	3.3	3.3	3.3	3.3	3.3	3.3	3.5	3.0		3.1	3.1	3.1	3.1	3.1	3.1	3.1	3.0		2.9	2.9	2.9	2.9	2.9	2.9	2.9

Boom length (m)	69.0								72.0							
Jib length (m)	13.0		19.0		25.0		31.0		13.0		19.0		25.0		31.0	
Offset angle	10°	30°	10°	30°	10°	30°	10°	30°	10°	30°	10°	30°	10°	30°	10°	30°
Working radius (m)																
18.0	18.2m ^x _{13.5}									18.7m ^x _{13.5}						
20.0	13.5		19.7m ^x _{12.0}							13.5			20.2m ^x _{12.0}			
22.0	13.5	22.1m ^x _{13.0}	12.0							13.5	22.6m ^x _{13.0}	12.0			22.9m ^x _{8.0}	
24.0	13.5	13.0	12.0	25.5m ^x _{8.0}	8.0			3.5		13.5	13.0	12.0		8.0		24.4m ^x _{3.5}
26.0	13.5	13.0	12.0	8.0	8.0			3.5		13.5	13.0	12.0		26m ^x _{8.0}	8.0	3.5
28.0	13.5	13.0	12.0	8.0	8.0	29.8m ^x _{6.0}	3.5			13.5	13.0	12.0	8.0	8.0		3.5
30.0	13.5	13.0	12.0	8.0	8.0	6.0	3.5			13.5	13.0	12.0	8.0	8.0	30.3m ^x _{6.0}	3.5
32.0	13.5	13.0	12.0	8.0	8.0	6.0	3.5	33.2m ^x _{3.0}		13.5	13.0	12.0	8.0	8.0	6.0	3.5
34.0	13.5	13.0	12.0	8.0	8.0	6.0	3.5	3.0		13.5	13.0	12.0	8.0	8.0	6.0	3.5
36.0	13.5	13.0	12.0	8.0	8.0	6.0	3.5	3.0		13.5	13.0	12.0	8.0	8.0	6.0	3.5
38.0	13.5	13.0	12.0	8.0	8.0	6.0	3.5	3.0		13.5	13.0	12.0	8.0	8.0	6.0	3.5
40.0	12.6	12.6	12.0	8.0	8.0	6.0	3.5	3.0		12.5	12.5	12.0	8.0	8.0	6.0	3.5
42.0	11.6	11.6	11.6	8.0	8.0	6.0	3.5	3.0		11.5	11.5	11.5	8.0	8.0	6.0	3.5
44.0	10.7	10.7	10.7	8.0	8.0	6.0	3.5	3.0		10.6	10.6	10.6	8.0	8.0	6.0	3.5
46.0	9.9	9.9	9.9	8.0	8.0	6.0	3.5	3.0		9.8	9.8	9.8	8.0	8.0	6.0	3.5
48.0	9.1	9.1	9.1	8.0	8.0	6.0	3.5	3.0		8.9	8.9	8.9	8.0	8.0	6.0	3.5
50.0	8.5	8.5	8.5	8.0	8.0	6.0	3.5	3.0		8.4	8.4	8.4	8.0	8.0	6.0	3.5
52.0	7.8	7.8	7.8	7.8	7.8	6.0	3.5	3.0		7.7	7.7	7.7	7.7	7.7	6.0	3.5
54.0	7.3	7.3	7.3	7.3	7.3	6.0	3.5	3.0		7.2	7.2	7.2	7.2	7.2	6.0	3.5
56.0	6.8	6.8	6.8	6.8	6.8	6.0	3.5	3.0		6.6	6.6	6.6	6.6	6.6	6.0	3.5
58.0	6.3	6.3	6.3	6.3	6.3	6.0	3.5	3.0		6.1	6.1	6.1	6.1	6.1	6.0	3.5
60.0	5.8	5.8	5.8	5.8	5.8	5.8	3.5	3.0		5.6	5.6	5.6	5.6	5.6	5.6	3.5
62.0	5.4	5.4	5.4	5.4	5.4	5.4	3.5	3.0		5.2	5.2	5.2	5.2	5.2	5.2	3.5
64.0	5.0	5.0	5.0	5.0	5.0	5.0	3.5	3.0		4.8	4.8	4.8	4.8	4.8	4.8	3.5
66.0	4.5	4.5	4.5	4.5	4.5	4.5	3.5	3.0		4.3	4.3	4.3	4.3	4.3	4.3	3.5
68.0	4.0	4.0	4.0	4.0	4.0	4.0	3.5	3.0		3.8	3.8	3.8	3.8	3.8	3.8	3.5
70.0	3.6	3.6	3.6	3.6	3.6	3.6	3.5	3.0		3.4	3.4	3.4	3.4	3.4	3.4	3.0
72.0	3.3	3.3	3.3	3.3	3.3	3.3	3.5	3.0		3.1	3.1	3.1	3.1	3.1	3.1	3.0
74.0	2.9	2.9	2.9	2.9	2.9	2.9	2.9	2.7		2.7	2.7	2.7	2.7	2.7	2.7	2.7

Notes

- Above rated loads are based on the machine being operated on firm level ground, within 78% of tipping load at any point of 360° around the machine with forward stability factor of over 1.15.
- Working radius is horizontal distance from center of rotation to a vertical line through the center of gravity of the load.
- When the main hook block is installed, the lifting loads of jib must be reduced by the weight of hook block (main and jib) and other lifting devices.
 150ton hook block...2.40ton
 100ton hook block...1.40ton
 60ton hook block...1.20ton
 50ton hook block...1.00ton
 30ton hook block...1.00ton
 13.5ton hook block...0.60ton
- Always extend the "A" frame during operation.
- Use the auxiliary jibs for crane operations only. Do not use for bucket operations.
- Rated loads for auxiliary jib are based on structural strength.
- Boom lengths for auxiliary jib attachment are 45.0m - 72.0m.

Specifications

Max. Lifting capacity×working radius		at Post	50.0metric tons×12.0m
		at Jib	25.0metric tons×13.6m
Max. lift above ground level		102.0m (57m post+51m jib)	
Rope speed	Main drum hoist/lowering	* 110~55/55~28m/min	
	Aux. drum hoist/lowering	* 110~55/55~28m/min	
	Post hoist/lowering	* 32~14m/min×2	
	Jib hoist/lowering	* 66~30m/min	
Part line	at Post	Hook block capacity×Part line	50ton×4
		Hook block capacity×Part line	25ton×2
	at Jib	Hook block capacity×Part line	25ton×2
		Hook block capacity×Part line	13.5ton×1
	Post hoist	18	
	Jib hoist	8	
Counterweight		64ton	
Total operating weight (with 57m post+50ton hook+51m jib+25ton hook+jib drum)		183ton	
Average ground bearing pressure		102kPa (1.04kg/cm ²)	

Note: The rope speed changes depending on the load.

Combination of Post and Jib

Jib length(m)	27	30	33	36	39	42	45	48	51
Post length (m)									
36	●	●							
39	●	●	●						
42	●	●	●	●					
45	●	●	●	●	●				
48	●	●	●	●	●	●			
51	●	●	●	●	●	●	●		
54	●	●	●	●	●	●	●	●	
57	●	●	●	●	●	●	●	●	●

Note: ●: Possible combinations

Wire Rope

Place of use	Rope diameter (mm)	Guaranteed strength(t)	Rope type
Main drum	φ28	70.2	P·S(19)+39×P.7
Aux. drum	φ28	70.2	P·S(19)+39×P.7
Jib hoist	φ26	49.9	IWRC6×WS(31)
Post hoist	φ22	36.3	IWRC6×WS(31)
Jib suspension	φ34	104.0	IWRC6×P·WS(36)
Strut suspension	φ34	104.0	IWRC6×P·WS(36)
Post suspension	φ34	104.0	IWRC6×P·WS(36)

Luffing jib crane Post/jib composition

Post composition

* The following table shows standard combinations of post lengths when ordering the maximum post length specification(57m).

Post length (m)	36.0	39.0	42.0	45.0	48.0	51.0	54.0	57.0
Post composition								
7.5m inner	1	1	1	1	1	1	1	1
*9.0m insert	1	1	1	1	1	1	1	1
*3.0m insert	1	1	1	1	1	1	1	1
3.0m insert	-	-	1	-	-	1	-	1
6.0m insert	1	-	-	1	-	-	1	1
9.0m insert	1	2	2	2	3	3	3	3
1.5m outer	1	1	1	1	1	1	1	1

Notes:

(*1) 9.0m and 3.0m insert posts with the *mark include guardrails for the middle equalizer.

(*2) A pendant cable for extending the jib is also included with the 3.0m—9.0m insert posts.

Jib composition

The following table shows standard combinations of jib lengths when ordering the maximum jib length specification.

Jib length (m)	27	30	33	36	39	42	45	48	51
Jib composition									
9.0m inner	1	1	1	1	1	1	1	1	1
3.0m insert	-	1	-	-	1	-	1	-	1
6.0m insert	-	-	1	-	-	1	1	2	2
9.0m insert	1	1	1	2	2	2	2	2	2
9.0m outer	1	1	1	1	1	1	1	1	1

Optional Auxiliary Jib performance

Specifications

Max. lifting load×working radius (with 36m post+27m jib)		13.5metric tons×26.0m (on jib hook)
Rope speed	Load hoist/lowering	110~55/55~28m/min
Part line	Optional aux. jib hoist ×Part line	13.5ton×1

Note: The rope speed changes depending on the load.

Jib combination

The auxiliary jib can be attached to all jibs from 27m to 51m.

Working range(No load condition)

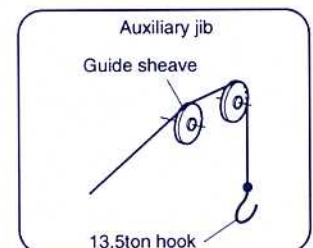
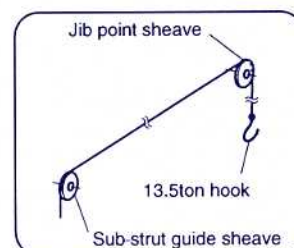
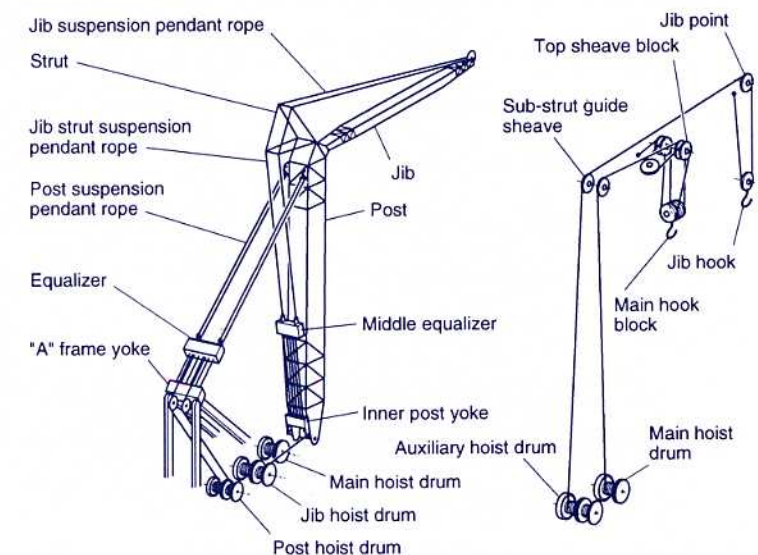
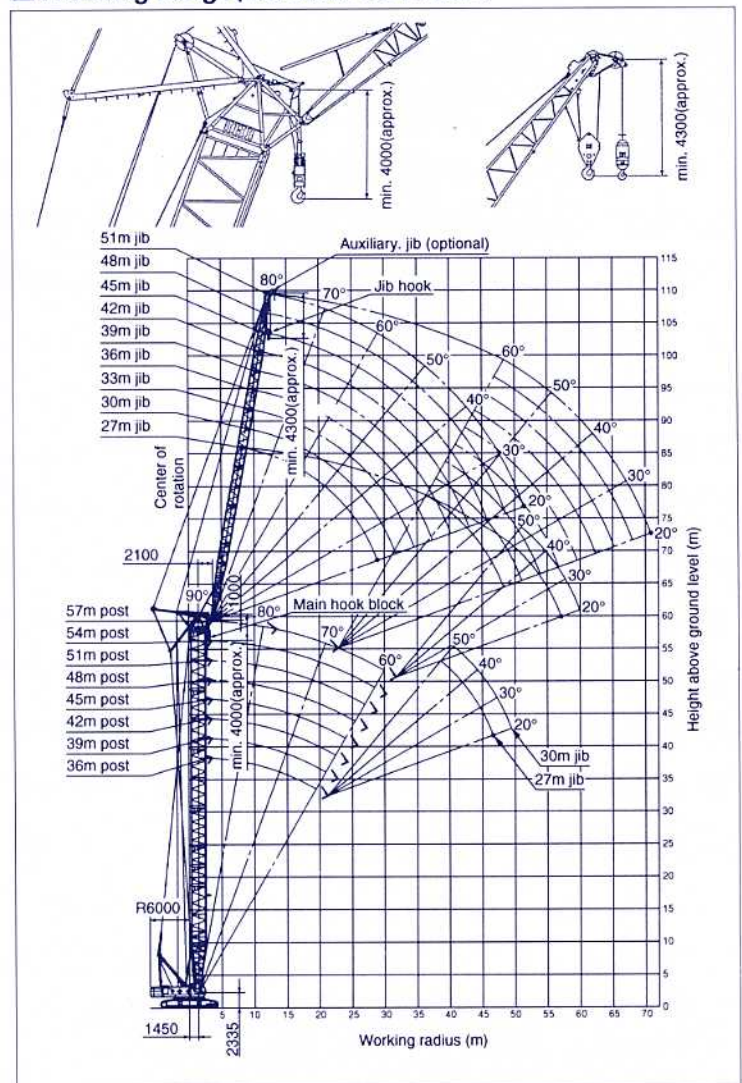

Luffing Jib Crane

CCH1500

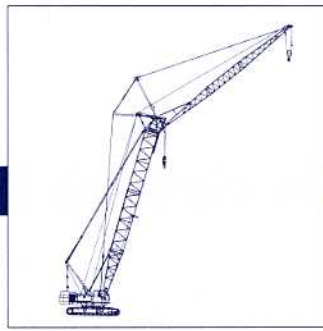

Post rated lifting loads (64 ton counterweight)

(Unit: metric ton)

Post length(m)	36.0						39.0								
Jib length(m)	27.0			30.0			27.0			30.0			33.0		
Working Jib offset angle range(m)	10~20°	20~40°	40°~	10~20°	20~40°	40°~	10~20°	20~40°	40°~	10~20°	20~40°	40°~	10~20°	20~40°	40°~
6.0	6.3m×50.0	6.3m×50.0	6.3m×50.0	6.3m×50.0	6.3m×50.0	6.3m×50.0	6.6m×50.0	6.6m×50.0	6.6m×50.0	6.6m×50.0	6.6m×50.0	6.6m×50.0	6.6m×50.0	6.6m×50.0	6.6m×50.0
7.0	50.0	50.0	50.0	50.0	50.0	50.0	50.0	50.0	50.0	50.0	50.0	50.0	50.0	50.0	50.0
8.0	50.0	50.0	50.0	50.0	50.0	50.0	50.0	50.0	50.0	50.0	50.0	50.0	50.0	50.0	50.0
9.0	50.0	50.0	50.0	50.0	50.0	50.0	50.0	50.0	50.0	50.0	50.0	50.0	50.0	50.0	9.9m×50.0
10.0	50.0	50.0	50.0	50.0	50.0	50.0	50.0	50.0	50.0	50.0	11.9m×50.0	11.9m×50.0	10.5m×50.0	10.1m×50.0	49.6
12.0	50.0	50.0	50.0	50.0	50.0	50.0	50.0	50.0	50.0	50.0	49.7	49.7	42.9	41.0	39.6
14.0	41.5	41.3	41.3	41.0	40.7	40.7	41.4	41.2	41.2	40.9	40.6	40.6	33.8	31.9	30.5
16.0	32.8	32.6	32.6	32.3	32.0	32.0	32.7	32.5	32.5	32.2	31.9	31.9	25.1	23.2	21.8
18.0	26.5	26.3	26.3	26.0	25.7	25.7	26.3	26.1	26.1	25.8	25.5	25.5	18.7	16.8	15.4
20.0	21.6	21.4	21.4	21.1	20.8	20.8	21.5	21.3	21.3	21.0	20.7	20.7	13.9	12.0	10.6
22.0	17.8	17.6	17.6	17.3	17.0	17.0	17.6	17.4	17.4	17.1	16.8	16.8	10.0	8.1	6.7
24.0	14.7	14.5	14.5	14.2	13.9	13.9	14.6	14.4	14.4	14.1	13.8	13.8	7.0	5.1	3.7
26.0	12.1	11.9	11.9	11.6	11.3	11.3	12.0	11.8	11.8	11.5	11.2	11.2	4.4	2.5	
28.0	10.0	9.8	9.8	9.5	9.2	9.2	9.9	9.7	9.7	9.4	9.1	9.1	2.3		
30.0	8.2	8.0	8.0	7.7	7.4	7.4	8.0	7.8	7.8	7.5	7.2	7.2			
32.0	6.6	6.4	6.4	6.1	5.8	5.8	6.5	6.3	6.3	6.0	5.7	5.7			
34.0	5.2	5.0	5.0	4.7	4.4	4.4	5.1	4.9	4.9	4.6	4.3	4.3			
36.0	34.3m×5.1	34.3m×4.9	34.3m×4.9	34.3m×4.6	34.3m×4.3	34.3m×4.3	3.9	3.7	3.7	3.4	3.1	3.1			
38.0							36.9m×3.4	36.9m×3.2	36.9m×3.2	36.9m×2.9	36.9m×2.6	36.9m×2.6			

Post length(m)	42.0						33.0			36.0			45.0		
Jib length(m)	27.0			30.0			33.0			36.0			27.0		
Working Jib offset angle range(m)	10~20°	20~40°	40°~	10~20°	20~40°	40°~	10~20°	20~40°	40°~	10~20°	20~40°	40°~	10~20°	20~40°	40°~
6.0	6.8m×50.0	6.8m×50.0	6.8m×50.0	6.8m×50.0	6.8m×50.0	6.8m×50.0	6.8m×50.0	6.8m×50.0	6.8m×50.0	6.8m×50.0	6.8m×50.0	6.8m×50.0			
7.0	50.0	50.0	50.0	50.0	50.0	50.0	50.0	50.0	50.0	50.0	50.0	50.0	7.1m×50.0	7.1m×50.0	7.1m×50.0
8.0	50.0	50.0	50.0	50.0	50.0	50.0	50.0	50.0	50.0	50.0	50.0	50.0	50.0	50.0	50.0
9.0	50.0	50.0	50.0	50.0	50.0	50.0	50.0	50.0	9.9m×50.0	50.0	50.0	9.7m×50.0	50.0	50.0	50.0
10.0	50.0	50.0	50.0	11.9m×50.0	11.9m×50.0	11.9m×50.0	10.5m×50.0	10.1m×50.0	49.5	10.4m×50.0	50.0	48.4	50.0	50.0	50.0
12.0	50.0	50.0	50.0	49.9	49.6	49.6	42.8	40.9	39.5	42.1	40.0	38.4	50.0	50.0	50.0
14.0	41.3	41.1	41.1	40.8	40.5	40.5	33.7	31.8	30.4	33.0	30.9	29.3	41.1	40.9	40.9
16.0	32.6	32.4	32.4	32.1	31.8	31.8	25.0	23.1	21.7	24.3	22.2	20.6	32.4	32.2	32.2
18.0	26.2	26.0	26.0	25.7	25.4	25.4	18.6	16.7	15.3	17.9	15.8	14.2	26.0	25.8	25.8
20.0	21.3	21.1	21.1	20.8	20.5	20.5	13.7	11.8	10.4	13.0	10.9	9.3	21.2	21.0	21.0
22.0	17.5	17.3	17.3	17.0	16.7	16.7	9.9	8.0	6.6	9.2	7.1	5.5	17.3	17.1	17.1
24.0	14.4	14.2	14.2	13.9	13.6	13.6	6.8	4.9	3.5	6.1	4.0	2.4	14.3	14.1	14.1
26.0	11.8	11.6	11.6	11.3	11.0	11.0	4.2	2.3		3.5			11.7	11.5	11.5
28.0	9.7	9.5	9.5	9.2	8.9	8.9	2.1						9.5	9.3	9.3
30.0	7.9	7.7	7.7	7.4	7.1	7.1							7.7	7.5	7.5
32.0	6.3	6.1	6.1	5.8	5.5	5.5							6.1	5.9	5.9
34.0	4.9	4.7	4.7	4.4	4.1	4.1							4.8	4.6	4.6
36.0	3.7	3.5	3.5	3.2	2.9	2.9							3.6	3.4	3.4
38.0	2.7	2.5	2.5	2.2									2.5	2.3	2.3

Post length(m)	45.0						36.0			39.0			48.0		
Jib length(m)	30.0			33.0			36.0			39.0			27.0		
Working Jib offset angle range(m)	10~20°	20~40°	40°~	10~20°	20~40°	40°~	10~20°	20~40°	40°~	10~20°	20~40°	40°~	10~20°	20~40°	40°~
6.0															
7.0	7.1m×50.0	7.1m×50.0	7.1m×50.0	7.1m×50.0	7.1m×50.0	7.1m×50.0	7.1m×50.0	7.1m×50.0	7.1m×50.0	7.1m×50.0	7.1m×50.0	7.1m×50.0	7.3m×50.0	7.3m×50.0	7.3m×50.0
8.0	50.0	50.0	50.0	50.0	50.0	50.0	50.0	50.0	50.0	50.0	50.0	50.0	50.0	50.0	50.0
9.0	50.0	50.0	50.0	50.0	50.0	50.0	9.8m×50.0	50.0	9.9m×50.0	9.6m×50.0	50.0	9.7m×50.0	9.2m×50.0	50.0	50.0
10.0	11.9m×50.0	11.9m×50.0	11.9m×50.0	10.5m×50.0	10.1m×50.0	49.3	10.3m×50.0	49.8	48.2	10.2m×50.0	48.6	46.4	50.0	50.0	50.0
12.0	49.7	49.4	49.4	42.6	40.7	39.3	41.9	39.8	38.2	41.1	38.6	36.4	50.0	50.0	50.0
14.0	40.6	40.3	40.3	33.5	31.6	30.2	32.8	30.7	29.1	32.0	29.5	27.3	41.0	40.8	40.8
16.0	31.9	31.6	31.6	24.8	22.9	21.5	24.1	22.0	20.4	23.3	20.8	18.6	32.3	32.1	32.1
18.0	25.5	25.2	25.2	18.4	16.5	15.1	17.7	15.6	14.0	16.9	14.4	12.2	25.9	25.7	25.7
20.0	20.7	20.4	20.4	13.6	11.7	10.3	12.9	10.8	9.2	12.1	9.6	7.4	21.0	20.8	20.8
22.0	16.8	16.5	16.5	9.7	7.8	6.4	9.0	6.9	5.3	8.2	5.7	3.5	17.2	17.0	17.0
24.0	13.8	13.5	13.5	6.7	4.8	3.4	6.0	3.9	2.3	5.2	2.7		14.1	13.9	13.9
26.0	11.2	10.9	10.9	4.1	2.2		3.4			2.6			11.5	11.3	11.3
28.0	9.0	8.7	8.7										9.4	9.2	9.2
30.0	7.2	6.9	6.9										7.6	7.4	7.4
32.0	5.6	5.3	5.3										6.0	5.8	5.8
34.0	4.3	4.0	4.0										4.6	4.4	4.4
36.0	3.1	2.8	2.8										3.4	3.2	3.2
38.0	2.0												2.3	2.1	2.1

Luffing Jib Crane

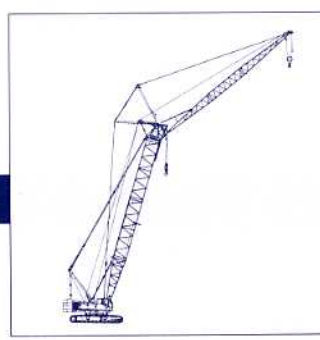

CCH1500

Post rated lifting loads (64 ton counterweight)

(Unit: metric ton)

Post length(m)		48.0														
Jib length(m)		30.0			33.0			36.0			39.0			42.0		
Working range(m)	Jib offset angle	10~20'	20~40'	40'~	10~20'	20~40'	40'~	10~20'	20~40'	40'~	10~20'	20~40'	40'~	10~20'	20~40'	40'~
	6.0															
7.0		7.3m×50.0	7.3m×50.0	7.3m×50.0	7.3m×50.0	7.3m×50.0	7.3m×50.0	7.3m×50.0	7.3m×50.0	7.3m×50.0	7.3m×50.0	7.3m×50.0	7.3m×50.0	7.3m×50.0	7.3m×50.0	7.3m×50.0
8.0		50.0	50.0	50.0	50.0	50.0	50.0	50.0	50.0	50.0	50.0	50.0	50.0	50.0	50.0	50.0
9.0		50.0	50.0	50.0	50.0	50.0	9.7m×50.0	50.0	9.9m×50.0	9.5m×50.0	50.0	9.6m×50.0	9.2m×50.0	50.0	9.4m×50.0	50.0
10.0		11.9m×50.0	11.8m×50.0	11.8m×50.0	10.4m×50.0	50.0	49.2	10.3m×50.0	49.7	48.1	10.1m×50.0	48.5	46.3	50.0	47.4	44.7
12.0		49.6	49.3	49.3	42.5	40.6	39.2	41.8	39.7	38.1	41.0	38.5	36.3	40.2	37.4	34.7
14.0		40.5	40.2	40.2	33.4	31.5	30.1	32.7	30.6	29.0	31.9	29.4	27.2	31.1	28.3	25.6
16.0		31.8	31.5	31.5	24.7	22.8	21.4	24.0	21.9	20.3	23.2	20.7	18.5	22.4	19.6	16.9
18.0		25.4	25.1	25.1	18.3	16.4	15.0	17.6	15.5	13.9	16.8	14.3	12.1	16.0	13.2	10.5
20.0		20.5	20.2	20.2	13.4	11.5	10.1	12.7	10.6	9.0	11.9	9.4	7.2	11.1	8.3	5.6
22.0		16.7	16.4	16.4	9.6	7.7	6.3	8.9	6.8	5.2	8.1	5.6	3.4	7.3	4.5	
24.0		13.6	13.3	13.3	6.5	4.6	3.2	5.8	3.7	2.1	5.0	2.5		4.2		
26.0		11.0	10.7	10.7	3.9	2.0		3.2			2.4					
28.0		8.9	8.6	8.6												
30.0		7.1	6.8	6.8												
32.0		5.5	5.2	5.2												
34.0		4.1	3.8	3.8												
36.0		2.9	2.6	2.6												
38.0																

Post length(m)		51.0														
Jib length(m)		27.0			30.0			33.0			36.0			39.0		
Working range(m)	Jib offset angle	10~20'	20~40'	40'~	10~20'	20~40'	40'~	10~20'	20~40'	40'~	10~20'	20~40'	40'~	10~20'	20~40'	40'~
	6.0															
7.0		7.6m×50.0	7.6m×50.0	7.6m×50.0	7.6m×50.0	7.6m×50.0	7.6m×50.0	7.6m×50.0	7.6m×50.0	7.6m×50.0	7.6m×50.0	7.6m×50.0	7.6m×50.0	7.6m×50.0	7.6m×50.0	7.6m×50.0
8.0		50.0	50.0	50.0	50.0	50.0	50.0	50.0	50.0	50.0	50.0	50.0	50.0	50.0	50.0	50.0
9.0		50.0	50.0	50.0	50.0	50.0	50.0	50.0	50.0	9.6m×50.0	50.0	9.8m×50.0	9.4m×50.0	50.0	9.5m×50.0	50.0
10.0		50.0	50.0	50.0	11.8m×50.0	11.7m×50.0	11.7m×50.0	10.3m×50.0	50.0	49.1	10.2m×50.0	49.6	48.0	50.0	48.4	46.2
12.0		50.0	50.0	50.0	49.5	49.2	49.2	42.4	40.5	39.1	41.7	39.6	38.0	40.9	38.4	36.2
14.0		40.9	40.7	40.7	40.4	40.1	40.1	33.3	31.4	30.0	32.6	30.5	28.9	31.8	29.3	27.1
16.0		32.1	31.9	31.9	31.6	31.3	31.3	24.5	22.6	21.2	23.8	21.7	20.1	23.0	20.5	18.3
18.0		25.8	25.6	25.6	25.3	25.0	25.0	18.2	16.3	14.9	17.5	15.4	13.8	16.7	14.2	12.0
20.0		20.9	20.7	20.7	20.4	20.1	20.1	13.3	11.4	10.0	12.6	10.5	8.9	11.8	9.3	7.1
22.0		17.1	16.9	16.9	16.6	16.3	16.3	9.5	7.6	6.2	8.8	6.7	5.1	8.0	5.5	3.3
24.0		14.0	13.8	13.8	13.5	13.2	13.2	6.4	4.5	3.1	5.7	3.6	2.0	4.9	2.4	
26.0		11.4	11.2	11.2	10.9	10.6	10.6	3.8			3.1			2.3		
28.0		9.2	9.0	9.0	8.7	8.4	8.4									
30.0		7.4	7.2	7.2	6.9	6.6	6.6									
32.0		5.8	5.6	5.6	5.3	5.0	5.0									
34.0		4.5	4.3	4.3	4.0	3.7	3.7									
36.0		3.3	3.1	3.1	2.8	2.5	2.5									
38.0		2.2	2.0	2.0												

Post length(m)		51.0									54.0					
Jib length(m)		42.0			45.0			27.0			30.0			33.0		
Working range(m)	Jib offset angle	10~20'	20~40'	40'~	10~20'	20~40'	40'~	10~20'	20~40'	40'~	10~20'	20~40'	40'~	10~20'	20~40'	40'~
	6.0															
7.0		7.6m×50.0	7.6m×50.0	7.6m×50.0	7.6m×50.0	7.6m×50.0	7.6m×50.0	7.9m×50.0	7.9m×50.0	7.9m×50.0	7.9m×50.0	7.9m×50.0	7.9m×50.0	7.9m×50.0	7.9m×50.0	7.9m×50.0
8.0		50.0	50.0	8.9m×50.0	50.0	50.0	8.9m×50.0	50.0	50.0	50.0	50.0	50.0	50.0	50.0	50.0	50.0
9.0		50.0	9.4m×50.0	49.6	9.8m×50.0	50.0	47.9	50.0	50.0	50.0	50.0	50.0	50.0	50.0	50.0	9.4m×50.0
10.0		50.0	47.3	44.6	49.4	45.9	42.9	11.9m×50.0	11.9m×50.0	11.9m×50.0	11.6m×50.0	11.5m×50.0	11.5m×50.0	10.1m×50.0	50.0	48.9
12.0		40.1	37.3	34.6	39.4	35.9	32.9	49.8	49.6	49.6	49.3	49.0	49.0	42.2	40.3	38.9
14.0		31.0	28.2	25.5	30.3	26.8	23.8	40.7	40.5	40.5	40.2	39.9	39.9	33.1	31.2	29.8
16.0		22.2	19.4	16.7	21.5	18.0	15.0	32.0	31.8	31.8	31.5	31.2	31.2	24.4	22.5	21.1
18.0		15.9	13.1	10.4	15.2	11.7	8.7	25.6	25.4	25.4	25.1	24.8	24.8	18.0	16.1	14.7
20.0		11.0	8.2	5.5	10.3	6.8	3.8	20.8	20.6	20.6	20.3	20.0	20.0	13.2	11.3	9.9
22.0		7.2	4.4		6.5	3.0		16.9	16.7	16.7	16.4	16.1	16.1	9.3	7.4	6.0
24.0		4.1			3.4			13.8	13.6	13.6	13.3	13.0	13.0	6.2	4.3	2.9
26.0								11.2	11.0	11.0	10.7	10.4	10.4	3.6		
28.0								9.1	8.9	8.9	8.6	8.3	8.3			
30.0								7.3	7.1	7.1	6.8	6.5	6.5			
32.0								5.7	5.5	5.5	5.2	4.9	4.9			
34.0								4.3	4.1	4.1	3.8	3.5	3.5			
36.0								3.1	2.9	2.9	2.6	2.3	2.3			
38.0								2.0								

Luffing Jib Crane

CCH1500



Post rated lifting loads (64 ton counterweight)

(Unit: metric ton)

Post length(m)	54.0															
Jib length(m)	36.0			39.0			42.0			45.0			48.0			
Jib offset angle	10~20°	20~40°	40°~	10~20°	20~40°	40°~	10~20°	20~40°	40°~	10~20°	20~40°	40°~	10~20°	20~40°	40°~	
Working radius (m)	10~20°	20~40°	40°~	10~20°	20~40°	40°~	10~20°	20~40°	40°~	10~20°	20~40°	40°~	10~20°	20~40°	40°~	
7.0	7.9m×50.0	7.9m×50.0	7.9m×50.0	7.9m×50.0	7.9m×50.0	7.9m×50.0	7.9m×50.0	7.9m×50.0	7.9m×50.0	7.9m×50.0	7.9m×50.0	7.9m×50.0	7.9m×50.0	7.9m×50.0	7.9m×50.0	
8.0	50.0	50.0	50.0	50.0	50.0	50.0	50.0	50.0	50.0	8.7m×50.0	50.0	50.0	8.5m×50.0	50.0	8.7m×50.0	48.9
9.0	50.0	9.6m×50.0	9.2m×50.0	50.0	9.3m×50.0	50.0	9.9m×50.0	50.0	49.4	9.8m×50.0	50.0	47.7	9.6m×50.0	48.9	45.6	
10.0	50.0	49.4	47.8	50.0	48.2	46.0	49.9	47.1	44.4	49.2	45.7	42.7	48.3	43.9	40.6	
12.0	41.5	39.4	37.8	40.7	38.2	36.0	39.9	37.1	34.4	39.2	35.7	32.7	38.3	33.9	30.6	
14.0	32.4	30.3	28.7	31.6	29.1	26.9	30.8	28.0	25.3	30.1	26.6	23.6	29.2	24.8	21.5	
16.0	23.7	21.6	20.0	22.9	20.4	18.2	22.1	19.3	16.6	21.4	17.9	14.9	20.5	16.1	12.8	
18.0	17.3	15.2	13.6	16.5	14.0	11.8	15.7	12.9	10.2	15.0	11.5	8.5	14.1	9.7	6.4	
20.0	12.5	10.4	8.8	11.7	9.2	7.0	10.9	8.1	5.4	10.2	6.7	3.7	9.3	4.9		
22.0	8.6	6.5	4.9	7.8	5.3	3.1	7.0	4.2		6.3	2.8		5.4			
24.0	5.5	3.4		4.7	2.2		3.9			3.2			2.3			
26.0	2.9			2.1												

Post length(m)	57.0														
Jib length(m)	27.0			30.0			33.0			36.0			39.0		
Jib offset angle	10~20°	20~40°	40°~	10~20°	20~40°	40°~	10~20°	20~40°	40°~	10~20°	20~40°	40°~	10~20°	20~40°	40°~
Working radius (m)	10~20°	20~40°	40°~	10~20°	20~40°	40°~	10~20°	20~40°	40°~	10~20°	20~40°	40°~	10~20°	20~40°	40°~
8.0	8.1m×50.0	8.1m×50.0	8.1m×50.0	8.1m×50.0	8.1m×50.0	8.1m×50.0	8.1m×50.0	8.1m×50.0	8.1m×50.0	8.1m×50.0	8.1m×50.0	8.1m×50.0	8.1m×50.0	8.1m×50.0	8.1m×50.0
9.0	50.0	50.0	50.0	50.0	50.0	50.0	50.0	50.0	9.3m×50.0	50.0	9.5m×50.0	9.1m×50.0	50.0	9.2m×50.0	50.0
10.0	11.9m×50.0	11.9m×50.0	11.9m×50.0	11.5m×50.0	11.4m×50.0	11.4m×50.0	50.0	50.0	48.8	50.0	49.3	47.7	50.0	48.1	45.9
12.0	49.7	49.5	49.5	49.2	48.9	48.9	42.1	40.2	38.8	41.4	39.3	37.7	40.6	38.1	35.9
14.0	40.6	40.4	40.4	40.1	39.8	39.8	33.0	31.1	29.7	32.3	30.2	28.6	31.5	29.0	26.8
16.0	31.9	31.7	31.7	31.4	31.1	31.1	24.3	22.4	21.0	23.6	21.5	19.9	22.8	20.3	18.1
18.0	25.5	25.3	25.3	25.0	24.7	24.7	17.9	16.0	14.6	17.2	15.1	13.5	16.4	13.9	11.7
20.0	20.6	20.4	20.4	20.1	19.8	19.8	13.0	11.1	9.7	12.3	10.2	8.6	11.5	9.0	6.8
22.0	16.8	16.6	16.6	16.3	16.0	16.0	9.2	7.3	5.9	8.5	6.4	4.8	7.7	5.2	3.0
24.0	13.7	13.5	13.5	13.2	12.9	12.9	6.1	4.2	2.8	5.4	3.3		4.6	2.1	
26.0	11.1	10.9	10.9	10.6	10.3	10.3	3.5			2.8			2.0		
28.0	8.9	8.7	8.7	8.4	8.1	8.1									
30.0	7.1	6.9	6.9	6.6	6.3	6.3									
32.0	5.5	5.3	5.3	5.0	4.7	4.7									
34.0	4.1	3.9	3.9	3.6	3.3	3.3									
36.0	2.9	2.7	2.7	2.4	2.1	2.1									

Post length(m)	57.0											
Jib length(m)	42.0			45.0			48.0			51.0		
Jib offset angle	10~20°	20~40°	40°~	10~20°	20~40°	40°~	10~20°	20~40°	40°~	10~20°	20~40°	40°~
Working radius (m)	10~20°	20~40°	40°~	10~20°	20~40°	40°~	10~20°	20~40°	40°~	10~20°	20~40°	40°~
8.0	8.1m×50.0	8.1m×50.0	8.1m×50.0	8.1m×50.0	8.1m×50.0	8.1m×50.0	8.1m×50.0	8.1m×50.0	8.1m×50.0	8.1m×50.0	8.1m×50.0	8.1m×50.0
9.0	9.9m×50.0	50.0	49.3	9.8m×50.0	50.0	47.6	9.6m×50.0	48.8	45.5	9.4m×50.0	47.0	43.3
10.0	49.8	47.0	44.3	49.1	45.6	42.6	48.2	43.8	40.5	47.1	42.0	38.3
12.0	39.8	37.0	34.3	39.1	35.6	32.6	38.2	33.8	30.5	37.1	32.0	28.3
14.0	30.7	27.9	25.2	30.0	26.5	23.5	29.1	24.7	21.4	28.0	22.9	19.2
16.0	22.0	19.2	16.5	21.3	17.8	14.8	20.4	16.0	12.7	19.3	14.2	10.5
18.0	15.6	12.8	10.1	14.9	11.4	8.4	14.0	9.6	6.3	12.9	7.8	4.1
20.0	10.7	7.9	5.2	10.0	6.5	3.5	9.1	4.7		8.0	2.9	
22.0	6.9	4.1		6.2	2.7		5.3			4.2		
24.0	3.8			3.1			2.2					

Notes

- Above rated loads are based on the machine being operated on firm level ground, within 78% of tipping load at any point of 360° around the machine with forward stability factor of over 1.15.
- The weight of hook blocks must be considered to be a part of the loads.
 - For post: 50ton hook block...1.00ton, 30ton hook block...1.00ton
 - For tower jib: 25ton hook block...1.00ton, 13.5ton hook block...0.60ton
- Depending on the number of part lines, rated load is limited as follows:
 - 2part line.....up to 25.0ton
 - 4part line.....up to 50.0ton
- The angle of the center line of the post and the center line of the jib (offset angle) must not be less than 10°.
- The angle of the center line of the jib to level ground (tower jib angle) must not be less than 20° under loaded conditions.
- When attaching the auxiliary jib, the post rated loads must be reduced by 1.5t from the figure shown in the above table.

Luffing Jib Crane

CCH1500



Jib rated lifting loads (64ton counterweight)

(Unit: metric ton)

Post length(m)	36.0								39.0										
	27.0				30.0				27.0				30.0				33.0		
Jib length(m)	27.0				30.0				27.0				30.0				33.0		
Post angle	90°	80°	70°	60°	90°	80°	70°	60°	90°	80°	70°	60°	90°	80°	70°	60°	90°	80°	70°
Working radius (m)	90°	80°	70°	60°	90°	80°	70°	60°	90°	80°	70°	60°	90°	80°	70°	60°	90°	80°	70°
8.0	8.3m×25.0				8.8m×23.4				8.3m×25.0				8.8m×23.4						
9.0	25.0				23.4				25.0				23.4					9.3m×22.2	
10.0	25.0				23.4				25.0				23.4					22.2	
12.0	13.6m×25.0				23.4				13.6m×25.0				23.4					22.2	
14.0	24.5				22.8				24.5				22.8					15.5m×22.2	
16.0	22.3				22.2				22.3				22.2					21.8	
18.0	20.2	19.0m×19.3			20.2				20.2	19.5m×18.9			20.2					20.2	
20.0	18.3	18.3			18.3	18.3			18.3	18.3			18.3	20.5m×18.0			18.3	21.5m×17.1	
22.0	16.8	16.8			16.7	16.7			16.8	16.8			16.7	16.7			16.7	16.7	
24.0	15.2	15.2			15.2	15.2			15.2	15.2			15.2	15.2			15.2	15.2	
26.0	13.9	13.9			13.9	13.9			13.9	13.9			13.9	13.9			13.9	13.9	
28.0	12.6	12.6	29.1m×12.0		12.6	12.6			12.6	12.6			12.6	12.6			12.6	12.6	
30.0	28.4m×12.3	11.5	11.5		11.5	11.5	30.6m×11.2		28.4m×12.3	11.5	30.1m×11.5		11.5	11.5	31.6m×10.8		11.5	11.5	
32.0		10.6	10.6		10.6	10.6	10.6			10.6	10.6			10.6	10.6		10.6	10.6	33.1m×10.2
34.0		9.8	9.8			9.8	9.8			9.8	9.8			9.8	9.8		9.8	9.8	9.8
36.0		34.7m×9.5	9.1			9.1	9.1			35.2m×9.3	9.1			9.1	9.1		34.1m×9.7	9.1	9.1
38.0			8.4	38.4m×8.3		37.5m×8.5	8.4				8.4	39.9m×7.8		8.4	8.4		8.4	8.4	8.4
40.0			7.8	7.8			7.8	40.4m×7.7			7.8	7.8		7.8	7.8		7.8	41.9m×7.3	7.8
42.0			40.6m×7.6	7.3			7.3	7.3		41.6m×7.3	7.3		7.3	7.3		7.3	7.3		40.8m×7.6
44.0				6.8			43.4m×6.9	6.8			6.8		6.8	6.8		6.8	6.8		6.8
46.0				6.4				6.4			6.4		6.4		44.4m×6.7	6.4	6.4		6.4
48.0				46.1m×6.3				6.1			47.6m×6.1					6.1			47.3m×6.1
50.0								49.0m×5.9										5.7	
52.0																		50.5m×5.6	

Post length(m)	42.0												45.0							
	27.0				30.0				33.0				36.0				27.0			
Jib length(m)	27.0				30.0				33.0				36.0				27.0			
Post angle	90°	80°	70°	60°	90°	80°	70°	60°	90°	80°	70°	60°	90°	80°	70°	60°	90°	80°	70°	60°
Working radius (m)	90°	80°	70°	60°	90°	80°	70°	60°	90°	80°	70°	60°	90°	80°	70°	60°	90°	80°	70°	60°
8.0	8.3m×25.0				8.8m×23.4												8.3m×25.0			
9.0	25.0				23.4					9.3m×22.2			9.8m×20.5				25.0			
10.0	25.0				23.4					22.2			20.5				25.0			
12.0	13.6m×25.0				23.4					22.2			20.5				13.6m×25.0			
14.0	24.5				22.8					15.5m×22.2			20.5				24.5			
16.0	22.3				22.2					21.8			20.1				22.3			
18.0	20.2				20.2					20.2			19.6				20.2			
20.0	18.3	18.3			18.3	21.0m×17.5				18.3			18.2				18.3	20.5m×17.9		
22.0	16.8	16.8			16.7	16.7				16.7	22.1m×16.7		16.6	23.1m×15.8			16.8	16.8		
24.0	15.2	15.2			15.2	15.2				15.2	15.2		15.1	15.1			15.2	15.2		
26.0	13.9	13.9			13.9	13.9				13.9	13.9		13.8	13.8			13.9	13.9		
28.0	12.6	12.6			12.6	12.6				12.6	12.6		12.5	12.5			12.6	12.6		
30.0	28.4m×12.3	11.5	31.2m×11.0		11.5	11.5				11.5	11.5		11.5	11.5			28.4m×12.3	11.5		
32.0		10.6	10.6		10.6	10.6	32.7m×10.4			10.6	10.6		10.6	10.6			10.6	10.6	32.2m×10.5	
34.0		9.8	9.8			9.8	9.8			9.8	9.8	34.2m×9.8	9.8	9.8	35.7m×9.2		9.8	9.8		
36.0		35.7m×9.2	9.1			9.1	9.1			34.1m×9.7	9.1	9.1	9.1	9.1	9.1		9.1	9.1		
38.0			8.4			8.4	8.4				8.4	8.4	36.9m×8.7	8.4	8.4		36.2m×9.0	8.4		
40.0			7.8	41.4m×7.4		38.5m×8.2	7.8				7.8	7.8		7.8	7.8			7.8		
42.0			7.3	7.3			7.3	43.4m×7.0		41.3m×7.4	7.3		7.3	7.3				7.3	42.9m×7.0	
44.0			42.7m×7.0	6.8				6.8	6.8		6.8		6.8	6.8				6.8	6.8	
46.0				6.4			45.5m×6.5	6.4			6.4		44.1m×6.7	6.4				6.4		
48.0				6.1				6.1			6.0			6.0				6.0		
50.0				49.1m×5.9				5.7			48.3m×5.9							5.6		5.8
52.0								5.4									51.1m×5.4			50.6m×5.7

Luffing Jib Crane

CC1500

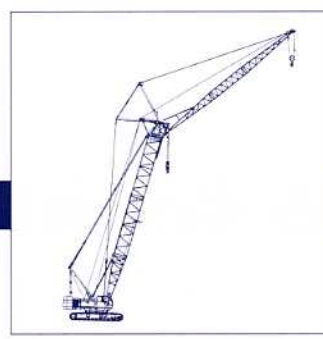

Jib rated lifting loads (64ton counterweight)

(Unit: metric ton)

Post length(m)	45.0															48.0			
	30.0				33.0			36.0			39.0			27.0					
Jib length(m)	30.0				33.0			36.0			39.0			27.0					
Post angle	90°	80°	70°	60°	90°	80°	70°	90°	80°	70°	90°	80°	70°	90°	80°	70°	60°		
Working radius (m)																			
8.0	8.8m x 23.4																	8.3m x 25.0	
9.0	23.4				9.3m x 22.2			9.8m x 20.5										25.0	
10.0	23.4				22.2			20.5					10.3m x 18.8					25.0	
12.0	23.4				22.2			20.5					18.8					13.6m x 25.0	
14.0	22.8				15.5m x 22.2			20.5					18.8					24.5	
16.0	22.2				21.8			20.1					18.8					22.3	
18.0	20.2				20.2			19.6					18.8					20.2	
20.0	18.3	21.6m x 17.1			18.3			18.2					17.7					18.3 21.0m x 17.5	
22.0	16.7	16.7			16.7	22.6m x 16.3		16.6	23.6m x 15.4				16.5					16.8 16.8	
24.0	15.2	15.2			15.2	15.2		15.1	15.1				15.1	24.6m x 14.7				15.2 15.2	
26.0	13.9	13.9			13.9	13.9		13.8	13.8				13.8	13.8				13.9 13.9	
28.0	12.6	12.6			12.6	12.6		12.5	12.5				12.5	12.5				12.6 12.6	
30.0	11.5	11.5			11.5	11.5		11.5	11.5				11.5	11.5				28.4m x 12.3 11.5	
32.0	31.3m x 10.8	10.6	33.7m x 10.0		10.6	10.6		10.6	10.6				10.6	10.6				10.6 33.2m x 10.1	
34.0		9.8	9.8		9.8	9.8	35.2m x 9.4	9.8	9.8				9.8	9.8				9.8 9.8	
36.0		9.1	9.1		34.1m x 9.7	9.1	9.1	9.1	9.1	36.7m x 8.8	9.1	9.1		9.1	9.1			9.1 9.1	
38.0		8.4	8.4			8.4	8.4	36.9m x 8.7	8.4	8.4	8.4	8.4	8.4	38.2m x 8.4				36.7m x 8.8 8.4	
40.0		39.0m x 8.0	7.8			7.8	7.8		7.8	7.8	39.7m x 7.8	7.8	7.8					7.8 7.8	
42.0			7.3			41.8m x 7.3	7.3		7.3	7.3		7.2	7.2					7.3 7.3	
44.0			6.8	44.9m x 6.6			6.8		6.8	6.8		6.8	6.8					6.8 6.8 44.4m x 6.6	
46.0			6.4	6.4			6.4		44.7m x 6.6	6.4		6.3	6.3					44.7m x 6.6 6.4	
48.0			46.5m x 6.3	6.1			6.0			6.0		47.5m x 6.0	5.9					6.1 6.1	
50.0				5.7			49.3m x 5.7				5.6		5.5					5.8 5.8	
52.0				5.4							5.3		5.2					5.5 5.5	
54.0					53.5m x 5.2						52.1m x 5.2			4.9				52.1m x 5.4 4.9	
56.0													55.0m x 4.7					55.0m x 4.7 4.9	

Post length(m)	48.0																
	30.0				33.0			36.0			39.0			42.0			
Jib length(m)	30.0				33.0			36.0			39.0			42.0			
Post angle	90°	80°	70°	60°	90°	80°	70°	90°	80°	70°	90°	80°	70°	90°	80°	70°	
Working radius (m)																	
8.0	8.8m x 23.4																
9.0	23.4				9.3m x 22.2			9.8m x 20.5									
10.0	23.4				22.2			20.5					10.3m x 18.8			10.9m x 17.0	
12.0	23.4				22.2			20.5					18.8			17.0	
14.0	22.8				15.5m x 22.2			20.5					18.8			14.5m x 17.0	
16.0	22.2				21.8			20.1					18.8			16.8	
18.0	20.2				20.2			19.6					18.8			16.5	
20.0	18.3				18.3			18.2					17.7			16.4	
22.0	16.7	22.1m x 16.7			16.7	23.1m x 15.9		16.6					16.5			15.6	
24.0	15.2	15.2			15.2	15.2		15.1	24.1m x 15.1				15.1	25.1m x 14.4		14.8	
26.0	13.9	13.9			13.9	13.9		13.8	13.8				13.8	13.8		26.2m x 13.7	
28.0	12.6	12.6			12.6	12.6		12.5	12.5				12.5	12.5		12.5 12.5	
30.0	11.5	11.5			11.5	11.5		11.5	11.5				11.5	11.5		11.4 11.4	
32.0	31.3m x 10.8	10.6			10.6	10.6		10.6	10.6				10.6	10.6		10.5 10.5	
34.0		9.8	34.7m x 9.6			9.8		9.8	9.8				9.8	9.8		9.7 9.7	
36.0		9.1	9.1		34.1m x 9.7	9.1	36.2m x 9.0	9.1	9.1	37.7m x 8.5	9.1	9.1		9.1	9.1	9.0 9.0	
38.0		8.4	8.4			8.4	8.4	36.9m x 8.7	8.4	8.4	8.4	8.4	8.4	39.2m x 8.0		8.3 8.3	
40.0		39.5m x 7.9	7.8			7.8	7.8		7.8	7.8		7.8	7.8	39.7m x 7.8		7.8 7.8 40.7m x 7.6	
42.0			7.3			7.3	7.3		7.3	7.3		7.2	7.2			7.2 7.2 7.2	
44.0			6.8			42.4m x 7.2	6.8		6.8	6.8		6.8	6.8		42.5m x 7.0	6.7 6.7	
46.0			6.4	46.4m x 6.3			6.4		45.2m x 6.5	6.4		6.3	6.3			6.3 6.3	
48.0			47.5m x 6.1	6.1			6.0			6.0		5.9	5.9			5.9 5.9	
50.0				5.7			5.6				5.6		5.5			5.4 5.4	
52.0				5.4			50.3m x 5.5				5.3		5.2			50.8m x 5.3 5.2	
54.0				5.1							53.2m x 5.1			4.9		4.9 4.9	
56.0					55.0m x 5.0									4.6			4.6 4.6
58.0																	4.3 4.3
60.0																	58.8m x 4.2 4.3

Luffing Jib Crane

CC1500



Jib rated lifting loads (64 ton counterweight)

(Unit: metric ton)

Post length(m)	51.0																			
	27.0				30.0				33.0				36.0				39.0			
Jib length(m)	27.0				30.0				33.0				36.0				39.0			
Post angle	90°	80°	70°	60°	90°	80°	70°	60°	90°	80°	70°	60°	90°	80°	70°	60°	90°	80°	70°	60°
Working radius(m)	90°	80°	70°	60°	90°	80°	70°	60°	90°	80°	70°	60°	90°	80°	70°	60°	90°	80°	70°	60°
8.0	8.3m×25.0				8.8m×23.4								9.8m×20.5							
9.0	25.0				23.4							9.3m×22.2								
10.0	25.0				23.4							22.2							10.3m×18.8	
12.0	13.6m×25.0				23.4							22.2							18.8	
14.0	24.5				22.8							15.5m×22.2							18.8	
16.0	22.3				22.2							21.8							18.8	
18.0	20.2				20.2							20.2							18.8	
20.0	18.3	21.6m×17.1			18.3							18.3							17.7	
22.0	16.8	16.8			16.7	22.6m×16.3						16.7	23.6m×15.5						16.5	
24.0	15.2	15.2			15.2	15.2						15.2	15.2				15.1	24.6m×14.7	15.1	25.7m×14.0
26.0	13.9	13.9			13.9	13.9						13.9	13.9				13.8	13.8	13.8	13.8
28.0	12.6	12.6			12.6	12.6						12.6	12.6				12.5	12.5	12.5	12.5
30.0	28.4m×12.3	11.5			11.5	11.5						11.5	11.5				11.5	11.5	11.5	11.5
32.0		10.6			31.3m×10.8	10.6						10.6	10.6				10.6	10.6	10.6	10.6
34.0		9.8	34.2m×9.7			9.8	35.7m×9.2					9.8	9.8				9.8	9.8	9.8	9.8
36.0		9.1	9.1			9.1	9.1					34.1m×9.7	9.1	37.2m×8.7			9.1	9.1	9.1	9.1
38.0		37.2m×8.6	8.4			8.4	8.4					8.4	8.4	36.9m×8.7	8.4	38.7m×8.2	8.4	8.4	8.4	8.4
40.0			7.8			7.8	7.8					7.8	7.8		7.8	7.8	39.7m×7.8	7.8	7.8	40.2m×7.7
42.0			7.3			40.1m×7.7	7.3					7.3	7.3		7.3	7.3		7.2	7.2	7.2
44.0		6.8	45.9m×6.4			6.8	6.8					42.9m×7.0	6.8	6.8	6.8	6.8	6.8	6.8	6.8	6.8
46.0		45.7m×6.4	6.4			6.4	47.9m×6.1					6.4	6.4	45.7m×6.4	6.4	6.4	6.4	6.4	6.3	6.3
48.0			6.1			6.1	6.1					6.0	6.0		6.0	6.0	6.0	6.0	5.9	5.9
50.0				5.8			48.6m×5.9	5.7				5.6	5.6		5.6	5.6	5.6	5.6	48.5m×5.7	5.5
52.0				5.5			5.4	5.4				5.4	5.4		5.3	5.3	5.3	5.3		5.2
54.0				53.6m×5.2			5.1	5.1							5.0	5.0	5.0	5.0		4.9
56.0							4.9	4.9							54.2m×4.9	4.9	4.9	4.9		4.6
58.0								56.5m×4.7												57.0m×4.4

Post length(m)	51.0								54.0											
	42.0				45.0				27.0				30.0				33.0			
Jib length(m)	42.0				45.0				27.0				30.0				33.0			
Post angle	90°	80°	70°	60°	90°	80°	70°	60°	90°	80°	70°	60°	90°	80°	70°	60°	90°	80°	70°	60°
Working radius(m)	90°	80°	70°	60°	90°	80°	70°	60°	90°	80°	70°	60°	90°	80°	70°	60°	90°	80°	70°	60°
8.0									8.3m×25.0				8.8m×23.4							
9.0									25.0				23.4							9.3m×22.2
10.0	10.9m×17.0				11.4m×15.2				25.0				23.4							22.2
12.0	17.0				15.2				13.6m×25.0				23.4							22.2
14.0	14.5m×17.0				15.2				24.5				22.8							15.5m×22.2
16.0	16.8				15.2				22.3				22.2							21.8
18.0	16.5				18.3m×15.2				20.2				20.2							20.2
20.0	16.4				14.8				18.3				18.3							18.3
22.0	15.6				14.3				16.8	22.1m×16.8			16.7	23.1m×15.9						16.7
24.0	14.8				13.7				15.2	15.2			15.2	15.2						15.2
26.0	13.8	26.7m×13.3			12.9	27.7m×12.2			13.9	13.9			13.9	13.9						13.9
28.0	12.5	12.5			12.1	12.1			12.6	12.6			12.6	12.6						12.6
30.0	11.4	11.4			11.3	11.3			28.4m×12.3	11.5			11.5	11.5						11.5
32.0	10.5	10.5			10.4	10.4			10.6				31.3m×10.8	10.6						10.6
34.0	9.7	9.7			9.7	9.7			9.8	35.3m×9.4			9.8							9.8
36.0	9.0	9.0			9.0	9.0			9.1	9.1			9.1	36.8m×8.8					34.1m×9.7	9.1
38.0	8.3	8.3			8.3	8.3			37.8m×8.4	8.4			8.4	8.4						8.4
40.0	7.8	7.8	41.7m×7.3		7.8	7.8			7.8	7.8			7.8	7.8						7.8
42.0	7.2	7.2	7.2		7.2	7.2	43.2m×6.9		7.2	7.2			40.6m×7.6	7.2						7.2
44.0	42.5m×7.0	6.7	6.7		6.7	6.7	6.7		6.8				6.8							43.4m×6.9
46.0		6.3	6.3		45.3m×6.3	6.2	6.2		6.4	47.4m×6.1			6.4	6.4						6.4
48.0		5.9	5.9		5.8	5.8			46.8m×6.2	6.0			6.0	6.0						6.0
50.0		5.4	5.4		5.3	5.3			5.6	5.6			5.6	49.6m×5.7	5.6					5.6
52.0		51.3m×5.2	5.1		5.0	5.0			5.3	5.3			5.3	5.3						5.3
54.0			4.8		4.7	4.7			5.1	5.1			5.1	5.1						5.1
56.0			4.5		54.2m×4.6	4.4			5.0	5.0			5.0	5.0						4.9
58.0			4.2		4.1	4.1			4.7	4.7			4.7	4.7						4.7
60.0			59.8m×3.9		3.8	3.8			3.8	3.8			3.8	3.8						
62.0					3.6	3.6			3.6	3.6			3.6	3.6						
64.0					62.7m×3.5	3.5			3.5	3.5			3.5	3.5						

Luffing Jib Crane

CCH1500

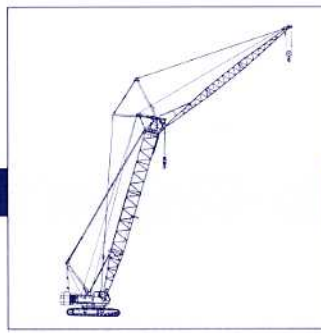

Jib rated lifting loads (64 ton counterweight)

(Unit: metric ton)

Post length(m)		54.0														
Jib length(m)		36.0			39.0			42.0			45.0			48.0		
Working radius(m)	Post angle	90°	80°	70°	90°	80°	70°	90°	80°	70°	90°	80°	70°	90°	80°	70°
	9.0	9.8m×20.5														
10.0	20.5				10.3m×18.8			10.9m×17.0			11.4m×15.2			11.9m×14.0		
12.0	20.5				18.8			17.0			15.2			14.0		
14.0	20.5				18.8			14.5m×17.0			15.2			14.0		
16.0	20.1				18.8			16.8			15.2			14.0		
18.0	19.6				18.8			16.5			18.3m×15.2			14.0		
20.0	18.2				17.7			16.4			14.8			13.4		
22.0	16.6				16.5			15.6			14.3			12.6		
24.0	15.1	25.2m×14.4			15.1			14.8			13.7			12.0		
26.0	13.8	13.8			13.8	26.2m×13.7		13.8	27.2m×13.0		12.9			11.5		
28.0	12.5	12.5			12.5	12.5		12.5	12.5		12.1	28.2m×12.0		11.0	29.3m×10.6	
30.0	11.5	11.5			11.5	11.5		11.4	11.4		11.3	11.3		10.4	10.4	
32.0	10.6	10.6			10.6	10.6		10.5	10.5		10.4	10.4		9.9	9.9	
34.0	9.8	9.8			9.8	9.8		9.7	9.7		9.7	9.7		9.4	9.4	
36.0	9.1	9.1			9.1	9.1		9.0	9.0		9.0	9.0		8.9	8.9	
38.0	36.9m×8.7	8.4	39.8m×7.9		8.4	8.4		8.3	8.3		8.3	8.3		8.3	8.3	
40.0		7.8	7.8	39.7m×7.8	7.8	41.3m×7.4		7.8	7.8		7.8	7.8		7.8	7.8	
42.0		7.2	7.2		7.2	7.2		7.2	7.2	42.8m×7.0	7.2	7.2		7.2	7.2	
44.0		6.8	6.8		6.8	6.8		6.8	6.8	42.5m×7.0	6.7	6.7	44.3m×6.6	6.7	6.7	45.8m×6.2
46.0		6.4	6.4		6.3	6.3		6.3	6.3		6.3	45.3m×6.3	6.2	6.2	6.1	6.1
48.0		46.2m×6.3	6.0		5.9	5.9		5.9	5.9		5.9	5.9	5.8	5.8	5.8	5.8
50.0			5.5		49.1m×5.7	5.5		5.4	5.4		5.4	5.4	5.3	5.3	48.2m×5.7	5.3
52.0			5.2			5.2		5.1	5.1		5.1	5.1	5.0	5.0	4.9	4.9
54.0			5.0			4.9		4.8	4.8		4.8	4.8	4.7	4.7	4.5	4.5
56.0			55.2m×4.8			4.6		4.5	4.5		4.5	4.5	54.7m×4.5	4.3	4.2	4.2
58.0						4.4			4.2		4.2	4.2	4.0		57.5m×4.0	3.9
60.0									3.9		3.9	3.9	3.7			3.7
62.0										60.9m×3.8			3.5			3.5
64.0													63.7m×3.2			3.2
66.0																3.0
68.0																66.5m×2.9

Post length(m)		57.0																
Jib length(m)		27.0				30.0				33.0			36.0			39.0		
Working radius(m)	Post angle	90°	80°	70°	60°	90°	80°	70°	60°	90°	80°	70°	90°	80°	70°	90°	80°	70°
	8.0	8.3m×25.0					8.8m×23.4											
9.0	25.0					23.4				9.3m×22.2			9.8m×20.5					
10.0	25.0					23.4				22.2			20.5			10.3m×18.8		
12.0	13.6m×25.0					23.4				22.2			20.5			18.8		
14.0	24.5					22.8				15.5m×22.2			20.5			18.8		
16.0	22.3					22.2				21.8			20.1			18.8		
18.0	20.2					20.2				20.2			19.6			18.1m×18.8		
20.0	18.3					18.3				18.3			18.2			17.7		
22.0	16.8	22.6m×16.2				16.7	23.6m×15.5			16.7			16.6			16.5		
24.0	15.2	15.2				15.2	15.2			15.2	24.7m×14.8		15.1	25.7m×14.0		15.1		
26.0	13.9	13.9				13.9	13.9			13.9	13.9		13.8	13.8		13.8	26.7m×13.3	
28.0	12.6	12.6				12.6	12.6			12.6	12.6		12.5	12.5		12.5	12.5	
30.0	28.4m×12.3	11.5				11.5	11.5			11.5	11.5		11.5	11.5		11.5	11.5	
32.0		10.6				31.3m×10.8	10.6			10.6	10.6		10.6	10.6		10.6	10.6	
34.0		9.8					9.8			9.8	9.8		9.8	9.8		9.8	9.8	
36.0		9.1	36.3m×9.0			9.1	37.8m×8.5			34.1m×9.7	9.1		9.1	9.1		9.1	9.1	
38.0		8.4	8.4			8.4	8.4			8.4	39.3m×8.0	36.9m×8.7	8.4	8.4		8.4	8.4	
40.0		38.3m×8.2	7.8			7.8	7.8			7.8	7.8		7.8	40.8m×7.5	39.7m×7.8	7.8	7.8	
42.0			7.2			41.1m×7.4	7.2			7.2	7.2		7.2	7.2		7.2	42.3m×7.2	
44.0			6.8				6.8			6.8	6.8		6.7	6.7		6.7	6.7	
46.0			6.2				6.2				6.2		6.2	6.2		6.2	6.2	
48.0			47.8m×5.8	48.9m×5.6			5.8			5.8			5.8	46.8m×6.0	5.8	5.8	5.8	5.8
50.0				5.4			5.4	50.9m×5.2			5.3		5.3		5.3	49.6m×5.3	5.3	5.3
52.0				5.0			5.0	50.7m×5.2			5.0		5.0		5.0		5.0	5.0
54.0				4.8			4.8				53.5m×4.8		4.7				4.7	4.7
56.0				4.5			4.3						4.3				4.3	4.3
58.0				56.7m×4.4			4.1						56.3m×4.2				4.0	4.0
60.0							59.5m×3.9										59.1m×3.8	3.8

Luffing Jib Crane

CCK1500



Jib rated lifting loads (64 ton counterweight)

Post length(m)	57.0											
	42.0			45.0			48.0			51.0		
Jib length(m)	Post angle			Post angle			Post angle			Post angle		
Working radius(m)	90°	80°	70°	90°	80°	70°	90°	80°	70°	90°	80°	70°
10.0	10.9m ^x 17.0			11.4m ^x 15.2			11.9m ^x 14.0					
12.0	17.0			15.2			14.0			12.4m ^x 13.1		
14.0	14.5m ^x 17.0			15.2			14.0			13.1		
16.0	16.8			15.2			14.0			13.1		
18.0	16.5			18.3m ^x 15.2			14.0			13.1		
20.0	16.4			14.8			13.4			12.8		
22.0	15.6			14.3			12.6			12.4		
24.0	14.8			13.7			12.0			12.0		
26.0	13.8	27.7m ^x 12.7		12.9			11.5			11.5		
28.0	12.5	12.5		12.1	28.8m ^x 11.8		11.0	29.8m ^x 10.4		11.0		
30.0	11.4	11.4		11.3	11.3		10.4	10.4		10.4	30.8m ^x 10.2	
32.0	10.5	10.5		10.4	10.4		9.9	9.9		9.8	9.9	
34.0	9.7	9.7		9.7	9.7		9.4	9.4		9.1	9.4	
36.0	9.0	9.0		9.0	9.0		8.9	8.9		8.5	8.9	
38.0	8.3	8.3		8.3	8.3		8.3	8.3		7.8	8.3	
40.0	7.8	7.8		7.8	7.8		7.8	7.8		7.3	7.8	
42.0	7.2	7.2	43.8m ^x 6.7	7.2	7.2		7.2	7.2		6.7	7.2	
44.0	42.5m ^x 7.0	6.7	6.7	6.7	6.7	45.3m ^x 6.3	6.7	6.7		6.2	6.5	
46.0		6.2	6.2	45.3m ^x 6.3	6.2	6.2	6.1	6.1	46.8m ^x 6.0	5.7	6.1	
48.0		5.8	5.8		5.8	5.8	5.8	5.8	46.8m ^x 6.0	5.2	5.7	48.3m ^x 5.6
50.0		5.3	5.3		5.3	5.3	48.2m ^x 5.7	5.3	5.3	4.7	5.2	5.2
52.0		5.0	5.0		5.0	5.0		4.9	4.9	51.0m ^x 4.4	4.8	4.8
54.0		52.4m ^x 4.8	4.7		4.7	4.7		4.5	4.5		4.4	4.4
56.0			4.3		55.2m ^x 4.4	4.3		4.2	4.2		4.1	4.1
58.0			4.0			4.0		3.9	3.9		3.8	3.8
60.0			3.7			3.7			3.7		3.5	3.5
62.0			3.5			3.5			3.5		60.8m ^x 3.4	3.3
64.0						3.2			3.2			3.1
66.0						64.7m ^x 3.1			3.0			2.9
68.0									67.5m ^x 2.8			2.7
70.0												2.6
72.0												70.3m ^x 2.5

(Unit: metric ton)

Notes

- Above rated loads are based on the machine being operated on firm level ground, within 78% of tipping load at any point of 360° around the machine with forward stability factor of over 1.15.
- The weight of hook blocks must be considered to be a part of the loads.
50ton hook block...1.00ton 30ton hook block...1.00ton
25ton hook block...1.00ton 13.5ton hook block...0.60ton
- Depending on the number of part lines, rated load is limited as follows:
1-part line.....up to 13.5ton
2-part line.....up to 25.0ton
- The angle of the center line of the post and the center line of the jib (offset angle) must not be less than 10°.
- The angle of the center line of the jib to level ground (tower jib angle) must not be less than 20° under loaded conditions.
- The auxiliary jib can be attached to all jibs (27m—51m).
- When attaching the auxiliary jib, the jib rated loads must be reduced by 0.5t from the figure shown in the above table.
- The rated loads of the auxiliary jib is equivalent to that of jib attached but to be reduced by 0.5ton. The maximum rated load of the auxiliary jib is 13.5ton

Specifications

Max. Lifting capacity×working radius		25.0metric tons×13.6m
Max. lift above ground level		102.0m (57m post+51m jib)
Rope speed	Main drum hoist/lowering	* 110~55/55~28m/min
	Post hoist/lowering	* 32~14m/min×2
	Jib hoist/lowering	* 110~55/55~28m/min
Part line	Main drum hoist	Hook block capacity×Part line
		25ton×2
	Post hoist	Hook block capacity×Part line
		13.5ton×1
	Post hoist	18
	Jib hoist	8
Counterweight		64ton
Total operating weight (with 57m post+51m jib+25ton hook)		179ton
Average ground bearing pressure		99kpa (1.01kg/cm ²)

Note: The rope speed changes depending on the load.

Combination of post and Jib

Jib length(m)	27	30	33	36	39	42	45	48	51
Post length(m)									
36	●	●							
39	●	●	●						
42	●	●	●	●					
45	●	●	●	●	●				
48	●	●	●	●	●	●			
51	●	●	●	●	●	●	●		
54	●	●	●	●	●	●	●	●	
57	●	●	●	●	●	●	●	●	●

Note: ●: Possible combinations

Wire Rope

Place of use	Rope diameter (mm)	Guaranteed strength(t)	Rope type
Hook hoist	φ28	70.2	P·S(19)+39×P.7
Jib hoist	φ26	49.9	IWRC6×WS(31)
Post hoist	φ22	36.3	IWRC6×WS(31)
Jib suspension	φ34	104.0	IWRC6×P·WS(36)
Strut suspension	φ34	104.0	IWRC6×P·WS(36)
Post suspension	φ34	104.0	IWRC6×P·WS(36)

Luffing tower crane post composition

The following table shows standard combinations of post lengths when ordering the maximum post length specification (57m).

Post length (m)	36.0	39.0	42.0	45.0	48.0	51.0	54.0	57.0
Post composition								
7.5m inner	1	1	1	1	1	1	1	1
*9.0m insert	1	1	1	1	1	1	1	1
*3.0m insert	1	1	1	1	1	1	1	1
3.0m insert	-	-	1	-	-	1	-	1
6.0m insert	1	-	-	1	-	-	1	1
9.0m insert	1	2	2	2	3	3	3	3
1.5m outer	1	1	1	1	1	1	1	1

Notes:

(*1) 9.0m and 3.0m insert posts with the *mark include guardrails for the middle equalizer.

(*2) A pendant cable for extending the jib is also included with the 3.0m-9.0m insert posts.

Jib composition

The following table shows standard combinations of jib lengths when ordering the maximum jib length specification.

Jib length (m)	27	30	33	36	39	42	45	48	51
Jib composition									
9.0m inner	1	1	1	1	1	1	1	1	1
3.0m insert	-	1	-	-	1	-	1	-	1
6.0m insert	-	-	1	-	-	1	1	2	2
9.0m insert	1	1	1	2	2	2	2	2	2
9.0m outer	1	1	1	1	1	1	1	1	1

Notes on 1m Auxiliary Jib

1. 1m Auxiliary Jib is fitted on the main boom length of 18 meter and up to 81 meter.

2. 1m Auxiliary Jib is to be used only for crane operation.

Working range (No load condition)

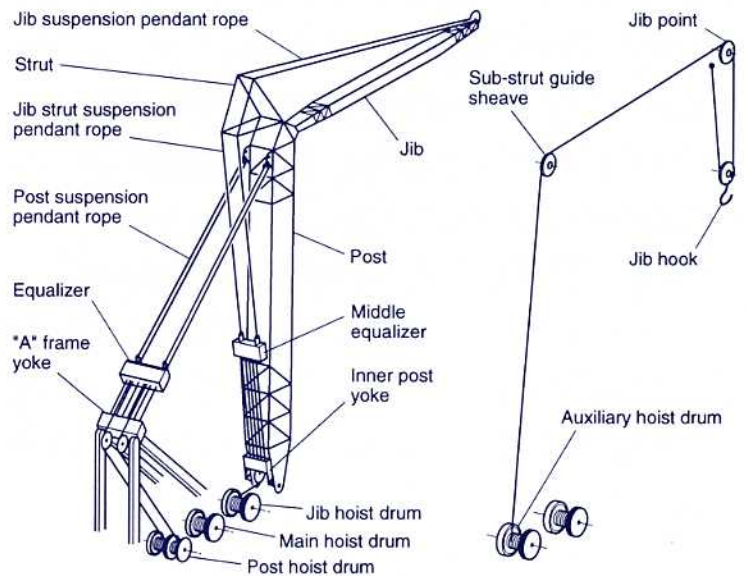
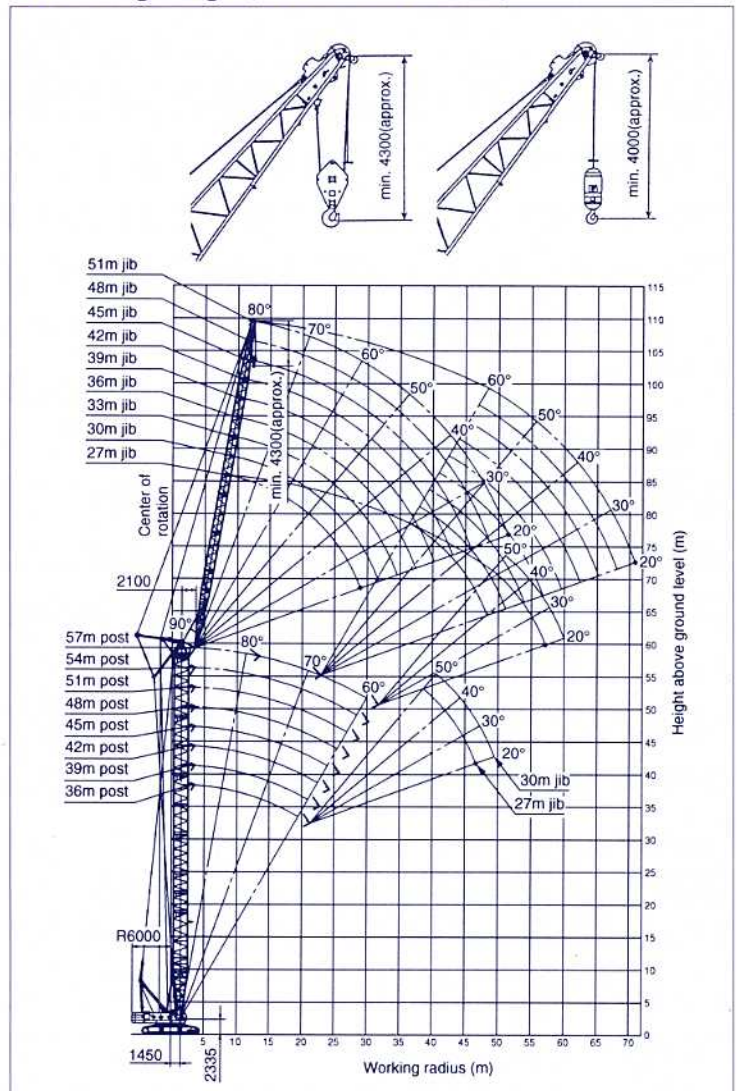

Luffing Tower Crane

CCK1500



Jib rated lifting loads (64 ton counterweight)

(Unit: metric ton)

Post length(m)	36.0								39.0										
	27.0				30.0				27.0				30.0				33.0		
Jib length(m)	27.0				30.0				27.0				30.0				33.0		
Post angle	90°	80°	70°	60°	90°	80°	70°	60°	90°	80°	70°	60°	90°	80°	70°	60°	90°	80°	70°
Working radius(m)	90°	80°	70°	60°	90°	80°	70°	60°	90°	80°	70°	60°	90°	80°	70°	60°	90°	80°	70°
8.0	8.3m×25.0				8.8m×23.4				8.3m×25.0				8.8m×23.4						
9.0	25.0				23.4				25.0				23.4				9.3m×22.2		
10.0	25.0				23.4				25.0				23.4				22.2		
12.0	13.6m×25.0				23.4				13.6m×25.0				23.4				22.2		
14.0	24.5				22.8				24.5				22.8				15.5m×22.2		
16.0	22.3				22.2				22.3				22.2				21.8		
18.0	20.2	19.0m×19.3			20.2				20.2	19.5m×18.9			20.2				20.2		
20.0	18.3	18.3			18.3	18.3			18.3	18.3			18.3	20.5m×18.0			18.3	21.5m×17.1	
22.0	16.8	16.8			16.7	16.7			16.8	16.8			16.7	16.7			16.7	16.7	
24.0	15.2	15.2			15.2	15.2			15.2	15.2			15.2	15.2			15.2	15.2	
26.0	13.9	13.9			13.9	13.9			13.9	13.9			13.9	13.9			13.9	13.9	
28.0	12.6	12.6	29.1m×12.0		12.6	12.6			12.6	12.6			12.6	12.6			12.6	12.6	
30.0	28.4m×12.3	11.5	11.5		11.5	11.5	30.6m×11.2		28.4m×12.3	11.5	30.1m×11.5		11.5	11.5	31.6m×10.8		11.5	11.5	
32.0		10.6	10.6		31.3m×10.8	10.6	10.6			10.6	10.6		31.3m×10.8	10.6	10.6		10.6	10.6	33.1m×10.2
34.0		9.8	9.8			9.8	9.8			9.8	9.8			9.8	9.8		9.8	9.8	9.8
36.0		34.7m×9.5	9.1			9.1	9.1			35.2m×9.3	9.1			9.1	9.1		34.1m×9.7	9.1	9.1
38.0			8.4	38.4m×8.3		37.5m×8.5	8.4				8.4	39.9m×7.8		8.4	8.4			8.4	8.4
40.0			7.8	7.8			7.8	40.4m×7.7			7.8	7.8		7.8	7.8		41.9m×7.3	7.8	7.8
42.0			40.6m×7.6	7.3			7.3	7.3		41.6m×7.3	7.3		7.3	7.3			7.3	7.3	40.8m×7.6
44.0				6.8			43.4m×6.9	6.8			6.8		6.8	6.8			6.8	6.8	6.8
46.0				6.4				6.4			6.4		6.4	6.4			44.4m×6.7	6.4	6.4
48.0				46.1m×6.3				6.1			47.6m×6.1						6.1		47.3m×6.1
50.0								49.0m×5.9									5.7		
52.0																	50.5m×5.6		

Post length(m)	42.0												45.0							
	27.0				30.0				33.0				36.0				27.0			
Jib length(m)	27.0				30.0				33.0				36.0				27.0			
Post angle	90°	80°	70°	60°	90°	80°	70°	60°	90°	80°	70°	60°	90°	80°	70°	60°	90°	80°	70°	60°
Working radius(m)	90°	80°	70°	60°	90°	80°	70°	60°	90°	80°	70°	60°	90°	80°	70°	60°	90°	80°	70°	60°
8.0	8.3m×25.0				8.8m×23.4								8.3m×25.0				8.3m×25.0			
9.0	25.0				23.4								9.3m×22.2				9.8m×20.5			25.0
10.0	25.0				23.4								22.2				20.5			25.0
12.0	13.6m×25.0				23.4								22.2				20.5			13.6m×25.0
14.0	24.5				22.8								15.5m×22.2				20.5			24.5
16.0	22.3				22.2								21.8				20.1			22.3
18.0	20.2				20.2								20.2				19.6			20.2
20.0	18.3	18.3			18.3	21.0m×17.5							18.3				18.2			18.3
22.0	16.8	16.8			16.7	16.7							16.7	22.1m×16.7			16.6	23.1m×15.8		16.8
24.0	15.2	15.2			15.2	15.2							15.2	15.2			15.1	15.1		15.2
26.0	13.9	13.9			13.9	13.9							13.9	13.9			13.8	13.8		13.9
28.0	12.6	12.6			12.6	12.6							12.6	12.6			12.5	12.5		12.6
30.0	28.4m×12.3	11.5	31.2m×11.0		11.5	11.5							11.5	11.5			11.5	11.5		28.4m×12.3
32.0		10.6	10.6		31.3m×10.8	10.6	32.7m×10.4						10.6	10.6			10.6	10.6		10.6
34.0		9.8	9.8			9.8	9.8						9.8	9.8	34.2m×9.8		9.8	9.8	35.7m×9.2	9.8
36.0		35.7m×9.2	9.1			9.1	9.1						34.1m×9.7	9.1	9.1	9.1	9.1	9.1	9.1	9.1
38.0			8.4			8.4	8.4							8.4	8.4	36.9m×8.7		8.4	8.4	36.2m×9.0
40.0			7.8	41.4m×7.4		38.5m×8.2	7.8							7.8	7.8			7.8	7.8	7.8
42.0			7.3	7.3			7.3	43.4m×7.0					41.3m×7.4	7.3			7.3	7.3		7.3
44.0			42.7m×7.0	6.8			6.8	6.8						6.8	6.8			6.8	6.8	43.7m×6.8
46.0				6.4			45.5m×6.5	6.4						6.4	6.4			44.1m×6.7	6.4	6.4
48.0				6.1				6.1						6.0					6.0	6.1
50.0				49.1m×5.9				5.7						48.3m×5.9					5.6	5.8
52.0								5.4											51.1m×5.4	50.6m×5.7

Luffing Tower Crane

CC1500

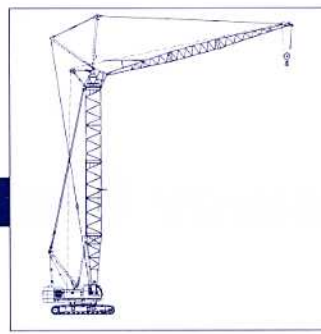

Jib rated lifting loads (64ton counterweight)

(Unit: metric ton)

Post length(m)	45.0													48.0					
	30.0				33.0			36.0			39.0			27.0					
Jib length(m)	30.0				33.0			36.0			39.0			27.0					
Post angle	90°	80°	70°	60°	90°	80°	70°	90°	80°	70°	90°	80°	70°	90°	80°	70°	60°		
Working radius(m)	90°	80°	70°	60°	90°	80°	70°	90°	80°	70°	90°	80°	70°	90°	80°	70°	60°		
8.0	8.8m×23.4																8.3m×25.0		
9.0	23.4				9.3m×22.2			9.8m×20.5									25.0		
10.0	23.4				22.2			20.5			10.3m×18.8						25.0		
12.0	23.4				22.2			20.5			18.8						13.6m×25.0		
14.0	22.8				15.5m×22.2			20.5			18.8						24.5		
16.0	22.2				21.8			20.1			18.8						22.3		
18.0	20.2				20.2			19.6			18.8						20.2		
20.0	18.3	21.6m×17.1			18.3			18.2			17.7						18.3	21.0m×17.5	
22.0	16.7	16.7			16.7	22.6m×16.3		16.6	23.6m×15.4		16.5						16.8	16.8	
24.0	15.2	15.2			15.2	15.2		15.1	15.1		15.1	24.6m×14.7					15.2	15.2	
26.0	13.9	13.9			13.9	13.9		13.8	13.8		13.8	13.8					13.9	13.9	
28.0	12.6	12.6			12.6	12.6		12.5	12.5		12.5	12.5					12.6	12.6	
30.0	11.5	11.5			11.5	11.5		11.5	11.5		11.5	11.5					28.4m×12.3	11.5	
32.0	31.3m×10.8	10.6	33.7m×10.0		10.6	10.6		10.6	10.6		10.6	10.6					10.6	33.2m×10.1	
34.0		9.8	9.8		9.8	9.8	35.2m×9.4	9.8	9.8		9.8	9.8					9.8	9.8	
36.0		9.1	9.1		34.1m×9.7	9.1	9.1	9.1	9.1	36.7m×8.8	9.1	9.1					9.1	9.1	
38.0		8.4	8.4			8.4	8.4	36.9m×8.7	8.4	8.4	8.4	8.4	38.2m×8.4				36.7m×8.8	8.4	
40.0		39.0m×8.0	7.8			7.8	7.8		7.8	7.8	39.7m×7.8	7.8	7.8					7.8	
42.0			7.3			41.8m×7.3	7.3		7.3	7.3		7.2	7.2					7.3	
44.0			6.8	44.9m×6.6			6.8		6.8	6.8		6.8	6.8					6.8	44.4m×6.6
46.0			6.4	6.4			6.4		44.7m×6.6	6.4		6.3	6.3					44.7m×6.5	6.4
48.0			46.5m×6.3	6.1			6.0			6.0		47.5m×6.0	5.9						6.1
50.0				5.7			49.3m×5.7				5.6		5.5						5.8
52.0				5.4							5.3								5.5
54.0				53.5m×5.2							52.1m×5.2								52.1m×5.4
56.0														55.0m×4.7					

Post length(m)	48.0													42.0				
	30.0				33.0			36.0			39.0			42.0				
Jib length(m)	30.0				33.0			36.0			39.0			42.0				
Post angle	90°	80°	70°	60°	90°	80°	70°	90°	80°	70°	90°	80°	70°	90°	80°	70°		
Working radius(m)	90°	80°	70°	60°	90°	80°	70°	90°	80°	70°	90°	80°	70°	90°	80°	70°		
8.0	8.8m×23.4																	
9.0	23.4				9.3m×22.2			9.8m×20.5										
10.0	23.4				22.2			20.5			10.3m×18.8					10.9m×17.0		
12.0	23.4				22.2			20.5			18.8					17.0		
14.0	22.8				15.5m×22.2			20.5			18.8					14.5m×17.0		
16.0	22.2				21.8			20.1			18.8					16.8		
18.0	20.2				20.2			19.6			18.8					16.5		
20.0	18.3				18.3			18.2			17.7					16.4		
22.0	16.7	22.1m×16.7			16.7	23.1m×15.9		16.6			16.5					15.6		
24.0	15.2	15.2			15.2	15.2		15.1	24.1m×15.1		15.1	25.1m×14.4				14.8		
26.0	13.9	13.9			13.9	13.9		13.8	13.8		13.8	13.8				13.8	26.2m×13.7	
28.0	12.6	12.6			12.6	12.6		12.5	12.5		12.5	12.5				12.5	12.5	
30.0	11.5	11.5			11.5	11.5		11.5	11.5		11.5	11.5				11.4	11.4	
32.0	31.3m×10.8	10.6			10.6	10.6		10.6	10.6		10.6	10.6				10.5	10.5	
34.0		9.8	34.7m×9.6		9.8	9.8		9.8	9.8		9.8	9.8				9.7	9.7	
36.0		9.1	9.1		34.1m×9.7	9.1	36.2m×9.0	9.1	9.1	37.7m×8.5	9.1	9.1				9.0	9.0	
38.0		8.4	8.4			8.4	8.4	36.9m×8.7	8.4	8.4	8.4	8.4	39.2m×8.0			8.3	8.3	
40.0		39.5m×7.9	7.8			7.8	7.8		7.8	7.8	39.7m×7.8	7.8	7.8			7.8	7.8	40.7m×7.6
42.0			7.3			7.3	7.3		7.3	7.3		7.2	7.2			7.2	7.2	7.2
44.0			6.8			42.4m×7.2	6.8		6.8	6.8		6.8	6.8			42.5m×7.0	6.7	6.7
46.0			6.4	46.4m×6.3			6.4		45.2m×6.5	6.4		6.3	6.3				6.3	6.3
48.0			47.5m×6.1	6.1			6.0			6.0		5.9	5.9				5.9	5.9
50.0				5.7			5.6				5.6		5.5				5.4	5.4
52.0				5.4			50.3m×5.5				5.3		5.2				50.8m×5.3	5.2
54.0				5.1							53.2m×5.1		4.9					4.9
56.0				55.0m×5.0									4.6					4.6
58.0																		4.3
60.0																		58.8m×4.2

Luffing Tower Crane

CCH1500

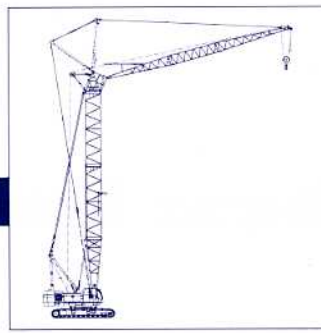

■Jib rated lifting loads (64 ton counterweight)

(Unit: metric ton)

Post length(m)	51.0																			
	27.0				30.0				33.0				36.0				39.0			
Jib length(m)	27.0				30.0				33.0				36.0				39.0			
Post angle	90°	80°	70°	60°	90°	80°	70°	60°	90°	80°	70°	60°	90°	80°	70°	60°	90°	80°	70°	
Working radius(m)	90°	80°	70°	60°	90°	80°	70°	60°	90°	80°	70°	60°	90°	80°	70°	60°	90°	80°	70°	
8.0	8.3m×25.0				8.8m×23.4															
9.0	25.0				23.4				9.3m×22.2				9.8m×20.5							
10.0	25.0				23.4				22.2				20.5					10.3m×18.8		
12.0	13.6m×25.0				23.4				22.2				20.5					18.8		
14.0	24.5				22.8				15.5m×22.2				20.5					18.8		
16.0	22.3				22.2				21.8				20.1					18.8		
18.0	20.2				20.2				20.2				19.6					18.8		
20.0	18.3	21.6m×17.1			18.3				18.3				18.2					17.7		
22.0	16.8	16.8			16.7	22.6m×16.3			16.7	23.6m×15.5			16.6					16.5		
24.0	15.2	15.2			15.2	15.2			15.2	15.2			15.1	24.6m×14.7			15.1	25.7m×14.0		
26.0	13.9	13.9			13.9	13.9			13.9	13.9			13.8	13.8			13.8	13.8		
28.0	12.6	12.6			12.6	12.6			12.6	12.6			12.5	12.5			12.5	12.5		
30.0	28.4m×12.3	11.5			11.5	11.5			11.5	11.5			11.5	11.5			11.5	11.5		
32.0		10.6			31.3m×10.8	10.6			10.6	10.6			10.6	10.6			10.6	10.6		
34.0		9.8	34.2m×9.7			9.8	35.7m×9.2		9.8	9.8			9.8	9.8			9.8	9.8		
36.0		9.1	9.1			9.1	9.1		34.1m×9.7	9.1	37.2m×8.7		9.1	9.1			9.1	9.1		
38.0		37.2m×8.6	8.4			8.4	8.4			8.4	8.4		36.9m×8.7	8.4	38.7m×8.2		8.4	8.4		
40.0			7.8			7.8	7.8			7.8	7.8			7.8	7.8		39.7m×7.8	7.8	40.2m×7.7	
42.0			7.3			40.1m×7.7	7.3			7.3	7.3			7.3	7.3		7.2	7.2		
44.0			6.8	45.9m×6.4			6.8			42.9m×7.0	6.8			6.8	6.8		6.8	6.8		
46.0			45.7m×6.4	6.4			6.4	47.9m×6.1			6.4			45.7m×6.4	6.4		6.4	6.3	6.3	
48.0				6.1			6.1	6.1			6.0				6.0			5.9	5.9	
50.0				5.8			48.6m×5.9	5.7			5.6				5.6			48.5m×5.7	5.5	
52.0				5.5				5.4			51.4m×5.4				5.3				5.2	
54.0				53.6m×5.2				5.1							5.0				4.9	
56.0								4.9							54.2m×4.9				4.6	
58.0								56.5m×4.7											57.0m×4.4	

Post length(m)	51.0									54.0								
	42.0			45.0			27.0			30.0			33.0					
Jib length(m)	42.0			45.0			27.0			30.0			33.0					
Post angle	90°	80°	70°	90°	80°	70°	90°	80°	70°	90°	80°	70°	90°	80°	70°			
Working radius(m)	90°	80°	70°	90°	80°	70°	90°	80°	70°	90°	80°	70°	90°	80°	70°			
8.0							8.3m×25.0						8.8m×23.4					
9.0							25.0						23.4		9.3m×22.2			
10.0	10.9m×17.0			11.4m×15.2			25.0						23.4		22.2			
12.0	17.0			15.2			13.6m×25.0						23.4		22.2			
14.0	14.5m×17.0			15.2			24.5						22.8		15.5m×22.2			
16.0	16.8			15.2			22.3						22.2		21.8			
18.0	16.5			18.3m×15.2			20.2						20.2		20.2			
20.0	16.4			14.8			18.3						18.3		18.3			
22.0	15.6			14.3			16.8	22.1m×16.8					16.7	23.1m×15.9	16.7			
24.0	14.8			13.7			15.2	15.2					15.2	15.2	15.2			
26.0	13.8	26.7m×13.3		12.9	27.7m×12.2		13.9	13.9					13.9	13.9	13.9			
28.0	12.5	12.5		12.1	12.1		12.6	12.6					12.6	12.6	12.6			
30.0	11.4	11.4		11.3	11.3		28.4m×12.3	11.5					11.5	11.5	11.5			
32.0	10.5	10.5		10.4	10.4			10.6					31.3m×10.8	10.6	10.6			
34.0	9.7	9.7		9.7	9.7			9.8	35.3m×9.4				9.8	9.8	9.8			
36.0	9.0	9.0		9.0	9.0			9.1	9.1				9.1	36.8m×8.8	34.1m×9.7			
38.0	8.3	8.3		8.3	8.3			37.8m×8.4	8.4				8.4	8.4	8.4			
40.0	7.8	7.8	41.7m×7.3	7.8	7.8				7.8				7.8	7.8	7.8			
42.0	7.2	7.2	7.2	7.2	7.2	43.2m×6.9			7.2				40.6m×7.6	7.2	7.2			
44.0	42.5m×7.0	6.7	6.7	6.7	6.7	6.7			6.8				6.8		43.4m×6.9			
46.0		6.3	6.3	45.3m×6.3	6.2	6.2			6.4	47.4m×6.1			6.4		6.4			
48.0		5.9	5.9		5.8	5.8			46.8m×6.2	6.0			6.0	49.4m×5.7	6.0			
50.0		5.4	5.4		5.3	5.3				5.6			49.6m×5.7	5.6	5.6			
52.0		51.3m×5.2	5.1		5.0	5.0				5.3				5.3	5.3			
54.0			4.8		4.7	4.7				5.1				5.1	52.4m×5.2			
56.0			4.5		54.2m×4.6	4.4				55.2m×5.0				4.9	4.9			
58.0			4.2			4.1								4.7				
60.0			59.8m×3.9			3.8												
62.0						3.6												
64.0						62.7m×3.5												

Luffing Tower Crane

CC11500

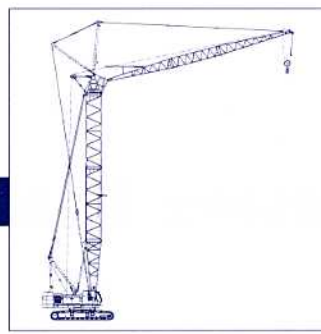

Jib rated lifting loads (64 ton counterweight)

(Unit: metric ton)

Post length(m)	54.0														
Jib length(m)	36.0			39.0			42.0			45.0			48.0		
Post angle	90°	80°	70°	90°	80°	70°	90°	80°	70°	90°	80°	70°	90°	80°	70°
Working radius(m)	90°	80°	70°	90°	80°	70°	90°	80°	70°	90°	80°	70°	90°	80°	70°
9.0	9.8m×20.5														
10.0	20.5			10.3m×18.8			10.9m×17.0			11.4m×15.2			11.9m×14.0		
12.0	20.5			18.8			17.0			15.2			14.0		
14.0	20.5			18.8			14.5m×17.0			15.2			14.0		
16.0	20.1			18.8			16.8			15.2			14.0		
18.0	19.6			18.8			16.5			18.3m×15.2			14.0		
20.0	18.2			17.7			16.4			14.8			13.4		
22.0	16.6			16.5			15.6			14.3			12.6		
24.0	15.1	25.2m×14.4		15.1			14.8			13.7			12.0		
26.0	13.8	13.8		13.8	26.2m×13.7		13.8	27.2m×13.0		12.9			11.5		
28.0	12.5	12.5		12.5	12.5		12.5	12.5		12.1	28.2m×12.0		11.0	29.3m×10.6	
30.0	11.5	11.5		11.5	11.5		11.4	11.4		11.3	11.3		10.4	10.4	
32.0	10.6	10.6		10.6	10.6		10.5	10.5		10.4	10.4		9.9	9.9	
34.0	9.8	9.8		9.8	9.8		9.7	9.7		9.7	9.7		9.4	9.4	
36.0	9.1	9.1		9.1	9.1		9.0	9.0		9.0	9.0		8.9	8.9	
38.0	36.9m×8.7	8.4	39.8m×7.9	8.4	8.4		8.3	8.3		8.3	8.3		8.3	8.3	
40.0		7.8	7.8	39.7m×7.8	7.8	41.3m×7.4	7.8	7.8		7.8	7.8		7.8	7.8	
42.0		7.2	7.2		7.2	7.2	7.2	7.2	42.8m×7.0	7.2	7.2		7.2	7.2	
44.0		6.8	6.8		6.8	6.8	42.5m×7.0	6.7	6.7	6.7	6.7	44.3m×6.6	6.7	6.7	45.8m×6.2
46.0		6.4	6.4		6.3	6.3		6.3	6.3	45.3m×6.3	6.2	6.2	6.1	6.1	6.1
48.0		46.2m×6.3	6.0		5.9	5.9		5.9	5.9		5.8	5.8	5.8	5.8	5.8
50.0			5.5		49.1m×5.7	5.5		5.4	5.4		5.3	5.3	48.2m×5.7	5.3	5.3
52.0			5.2			5.2		5.1	5.1		5.0	5.0		4.9	4.9
54.0			5.0			4.9			4.8		4.7	4.7		4.5	4.5
56.0			55.2m×4.8			4.6			4.5		54.7m×4.5	4.3		4.2	4.2
58.0						4.4			4.2			4.0		57.5m×4.0	3.9
60.0									3.9			3.7			3.7
62.0									60.9m×3.8			3.5			3.5
64.0												63.7m×3.2			3.2
66.0															3.0
68.0															66.5m×2.9

Post length(m)	57.0																
Jib length(m)	27.0				30.0				33.0			36.0			39.0		
Post angle	90°	80°	70°	60°	90°	80°	70°	60°	90°	80°	70°	90°	80°	70°	90°	80°	70°
Working radius(m)	90°	80°	70°	60°	90°	80°	70°	60°	90°	80°	70°	90°	80°	70°	90°	80°	70°
8.0	8.3m×25.0				8.8m×23.4												
9.0	25.0				23.4				9.3m×22.2			9.8m×20.5					
10.0	25.0				23.4				22.2			20.5			10.3m×18.8		
12.0	13.6m×25.0				23.4				22.2			20.5			18.8		
14.0	24.5				22.8				15.5m×22.2			20.5			18.8		
16.0	22.3				22.2				21.8			20.1			18.8		
18.0	20.2				20.2				20.2			19.6			18.1m×18.8		
20.0	18.3				18.3				18.3			18.2			17.7		
22.0	16.8	22.6m×16.2			16.7	23.6m×15.5			16.7			16.6			16.5		
24.0	15.2	15.2			15.2	15.2			15.2	24.7m×14.8		15.1	25.7m×14.0		15.1		
26.0	13.9	13.9			13.9	13.9			13.9	13.9		13.8	13.8		13.8	26.7m×13.3	
28.0	12.6	12.6			12.6	12.6			12.6	12.6		12.5	12.5		12.5	12.5	
30.0	28.4m×12.3	11.5			11.5	11.5			11.5	11.5		11.5	11.5		11.5	11.5	
32.0		10.6			31.3m×10.8	10.6			10.6	10.6		10.6	10.6		10.6	10.6	
34.0		9.8				9.8			9.8	9.8		9.8	9.8		9.8	9.8	
36.0		9.1	36.3m×9.0			9.1	37.8m×8.5		34.1m×9.7	9.1		9.1	9.1		9.1	9.1	
38.0		8.4	8.4			8.4	8.4		8.4	8.4	39.3m×8.0	36.9m×8.7	8.4		8.4	8.4	
40.0		38.3m×8.2	7.8			7.8	7.8		7.8	7.8			7.8	40.8m×7.5	39.7m×7.8	7.8	
42.0			7.2			41.1m×7.4	7.2		7.2	7.2			7.2	7.2	7.2	7.2	42.3m×7.2
44.0			6.8				6.8			6.8			6.7	6.7		6.7	6.7
46.0			6.2				6.2			6.2			6.2	6.2		6.2	6.2
48.0			47.8m×5.8	48.9m×5.6			5.8			5.8			46.8m×6.0	5.8		5.8	5.8
50.0				5.4			5.4	50.9m×5.2		5.3			5.3		49.6m×5.3	5.3	
52.0				5.0			50.7m×5.2	5.0		5.0			5.0			5.0	5.0
54.0				4.8				4.8		53.5m×4.8			4.7			4.7	4.7
56.0				4.5				4.3					4.3			4.3	4.3
58.0				56.7m×4.4				4.1					56.3m×4.2			4.0	4.0
60.0								59.5m×3.9								59.1m×3.8	

Luffing Tower Crane

CCH1500

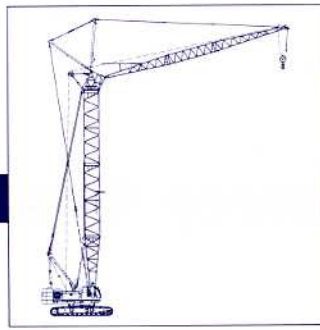

Jib rated lifting loads (64 ton counterweight)

(Unit: metric ton)

Post length(m)	57.0											
Jib length(m)	42.0			45.0			48.0			51.0		
Post angle	90°	80°	70°	90°	80°	70°	90°	80°	70°	90°	80°	70°
Working radius(m)	90°	80°	70°	90°	80°	70°	90°	80°	70°	90°	80°	70°
10.0	10.9m× 17.0			11.4m× 15.2			11.9m× 14.0					
12.0	17.0			15.2			14.0			12.4m× 13.1		
14.0	14.5m× 17.0			15.2			14.0			13.1		
16.0	16.8			15.2			14.0			13.1		
18.0	16.5			18.3m× 15.2			14.0			13.1		
20.0	16.4			14.8			13.4			12.8		
22.0	15.6			14.3			12.6			12.4		
24.0	14.8			13.7			12.0			12.0		
26.0	13.8	27.7m× 12.7		12.9			11.5			11.5		
28.0	12.5	12.5		12.1	28.8m× 11.8		11.0	29.8m× 10.4		11.0		
30.0	11.4	11.4		11.3	11.3		10.4	10.4		10.4	30.8m× 10.2	
32.0	10.5	10.5		10.4	10.4		9.9	9.9		9.8	9.9	
34.0	9.7	9.7		9.7	9.7		9.4	9.4		9.1	9.4	
36.0	9.0	9.0		9.0	9.0		8.9	8.9		8.5	8.9	
38.0	8.3	8.3		8.3	8.3		8.3	8.3		7.8	8.3	
40.0	7.8	7.8		7.8	7.8		7.8	7.8		7.3	7.8	
42.0	7.2	7.2	43.8m× 6.7	7.2	7.2		7.2	7.2		6.7	7.2	
44.0	42.5m× 7.0	6.7	6.7	6.7	6.7	45.3m× 6.3	6.7	6.7		6.2	6.5	
46.0		6.2	6.2	45.3m× 6.3	6.2	6.2	6.1	6.1	46.8m× 6.0	5.7	6.1	
48.0		5.8	5.8		5.8	5.8	5.8	5.8	5.8	5.2	5.7	48.3m× 5.6
50.0		5.3	5.3		5.3	5.3	48.2m× 5.7	5.3	5.3	4.7	5.2	5.2
52.0		5.0	5.0		5.0	5.0		4.9	4.9	51.0m× 4.4	4.8	4.8
54.0		52.4m× 4.8	4.7		4.7	4.7		4.5	4.5		4.4	4.4
56.0			4.3		55.2m× 4.4	4.3		4.2	4.2		4.1	4.1
58.0			4.0			4.0		3.9	3.9		3.8	3.8
60.0			3.7			3.7			3.7		3.5	3.5
62.0			3.5			3.5			3.5		60.8m× 3.4	3.3
64.0						3.2			3.2			3.1
66.0						64.7m× 3.1			3.0			2.9
68.0									67.5m× 2.8			2.7
70.0												2.6
72.0												70.3m× 2.5

Notes

- Above rated loads are based on firm level ground, within 78% of tipping load at any point 360° throughout and with front stability of 1.15 or more.
- The actual lifting loads must be reduced following hook block (main and jib) and other lifting devices.
For tower jib
25ton hook block...1.00ton
13.5ton hook block...0.60ton
- Depending on the number of part lines, rated load is limited as follows:
1-part line...up to 13.5ton
2-part line...up to 25.0ton
- The angle of the center line of the post and the center line of the jib (offset angle) must not be less than 10°.
- The angle of the center line of the jib to level ground (tower jib angle) must not be less than 20° under loaded conditions.

Post Crane

CCH1500



Specifications

Max. lifting capacity×working radius		50.0metric tons×14.0m
Max. lift above ground level		55.0m (at 57m post)
Rope speed	Main drum hoist/lowering	* 110~55/55~28m/min
	Post hoist/lowering	* 32~14m/min×2
Part line	Main drum hoist	Hook block capacity×Part line
		50ton×4
	Post hoist	Hook block capacity×Part line
		25ton×2
		18
Counterweight		64.0ton
Total operating weight (with 57m post + 50ton hook)		170.0ton
Average ground bearing pressure		94kpa(0.96kg/cm ²)

Note:The rope speed changes depending on the load.

Working range (No load condition)

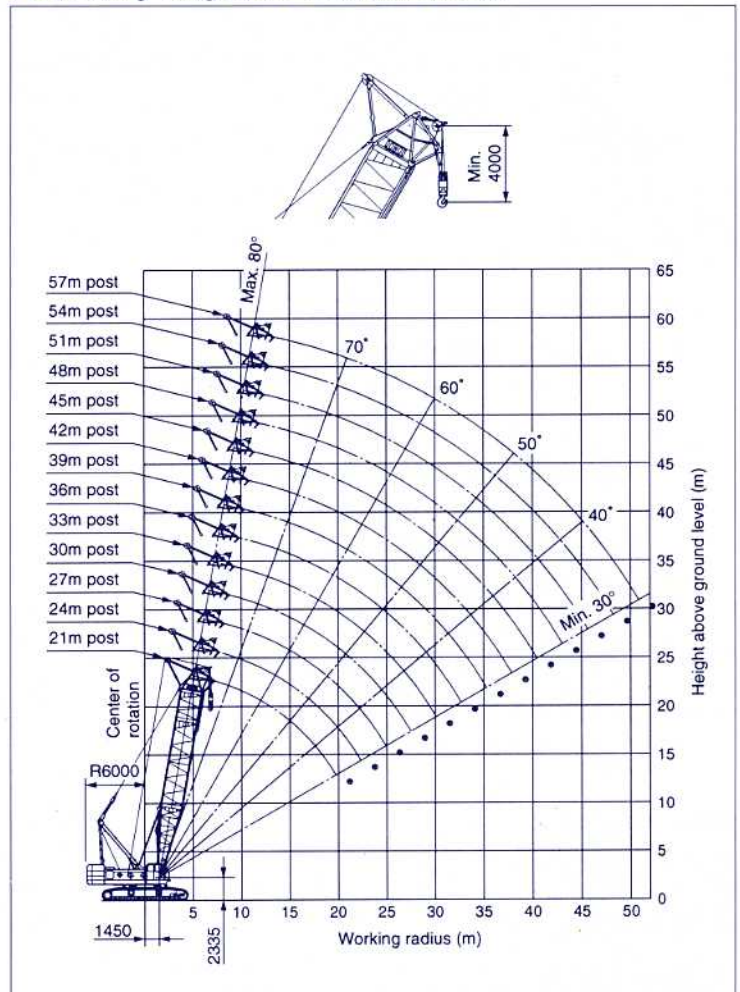

Notes

- Above rated loads are based on firm level ground, within 78% of tipping load at any point 360° throughout and with front stability of 1.15 or more.
- Working radius is horizontal distance from center of rotation to a vertical line through the center of gravity of the load.
- The actual lifting loads must be reduced following hook block and other lifting devices.
 50ton hook block.....1.00ton 30ton hook block.....1.00ton
 13.5ton hook block.....0.6ton
- Depending on the number of part lines, rated lifting load is limited as follows:
 2Part line.....up to25.0ton
 4Part line.....up to50.0ton

Post rated lifting loads (64ton counterweight)

(Unit: metric ton)

Boom length (m) / Working radius (m)	21.0	24.0	27.0	30.0	33.0	36.0	39.0	42.0	45.0	48.0	51.0	54.0	57.0
6.0	6.9m × 50.0												
7.0	50.0	7.4m × 50.0	7.9m × 50.0										
8.0	50.0	50.0	50.0	8.4m × 50.0									
9.0	50.0	50.0	50.0	50.0	9.0m × 50.0	9.5m × 50.0							
10.0	50.0	50.0	50.0	50.0	50.0	50.0	10.0m × 50.0	10.5m × 50.0	11.0m × 50.0	11.6m × 50.0			
12.0	50.0	50.0	50.0	50.0	50.0	13.9m × 50.0	13.9m × 50.0	13.9m × 50.0	13.8m × 50.0	13.8m × 50.0	12.1m × 50.0	12.6m × 50.0	13.1m × 50.0
14.0	50.0	50.0	50.0	50.0	50.0	49.9	49.8	49.7	49.5	49.4	49.3	49.1	49.0
16.0	41.9	41.8	41.6	41.5	41.4	41.2	41.1	41.0	40.8	40.7	40.5	40.4	40.3
18.0	35.6	35.4	35.3	35.1	35.0	34.9	34.7	34.6	34.4	34.3	34.2	34.0	33.9
20.0	30.7	30.6	30.4	30.3	30.2	30.0	29.9	29.7	29.6	29.4	29.3	29.2	29.0
22.0	21.3m × 28.2	26.8	26.6	26.5	26.3	26.2	26.0	25.9	25.7	25.6	25.5	25.3	25.2
24.0		23.9m × 23.7	23.6	23.4	23.3	23.1	23.0	22.8	22.7	22.5	22.4	22.2	22.1
26.0			21.0	20.9	20.7	20.5	20.4	20.2	20.1	19.9	19.8	19.6	19.5
28.0			26.5m × 20.4	18.7	18.6	18.4	18.3	18.1	17.9	17.8	17.6	17.5	17.3
30.0				29.1m × 17.7	16.7	16.6	16.4	16.3	16.1	16.0	15.8	15.7	15.5
32.0					31.7m × 15.4	15.0	14.9	14.7	14.5	14.4	14.2	14.1	13.9
34.0						13.6	13.5	13.3	13.2	13.0	12.9	12.7	12.5
36.0						34.3m × 13.5	12.3	12.1	12.0	11.8	11.7	11.5	11.3
38.0							36.9m × 11.8	11.1	10.9	10.7	10.6	10.4	10.3
40.0								39.5m × 10.3	10.0	9.8	9.6	9.5	9.3
42.0									9.1	8.9	8.8	8.6	8.5
44.0									42.1m × 9.1	8.2	8.0	7.9	7.7
46.0										44.7m × 7.9	7.3	7.2	7.0
48.0											47.3m × 6.9	6.5	6.4
50.0												49.9m × 5.9	5.7
52.0													5.0

Individual masses and outline dimensions

	Main part name	Mass (tons)	Q'ty	dimensions(m)L×W×H																								
Main body	Main body (without "A" frame, ropes, axles and crawlers)	(31.9)	(1)	7.95×3.37×3.17																								
	Main body (with "A" frame, and without ropes, axles and crawlers)	(36.2)	(1)	9.60×3.37×3.32																								
	Main body (with "A" frame, ropes, and axles, and without crawlers)	47.3	1	10.17×3.37×3.33																								
	Crawler	18.9	2	8.87×1.07×1.37																								
	Counterweight (standard)	64.0	5	4.37×1.80×1.52																								
	Additional counterweight	30.0	4	See below.																								
	Counterweight arrangement and dimensions (mm)				<table border="1"> <thead> <tr> <th colspan="2">Weight (tons)</th> </tr> </thead> <tbody> <tr><td>①</td><td>18.5</td></tr> <tr><td>②</td><td>18.6</td></tr> <tr><td>③</td><td>9.8</td></tr> <tr><td>④</td><td>7.5</td></tr> <tr><td>⑤</td><td>9.6</td></tr> <tr><td>⑥</td><td>6.2</td></tr> <tr><td>⑦</td><td>7.8</td></tr> <tr><td>⑧</td><td>8.0</td></tr> <tr><td>⑨</td><td>8.0</td></tr> <tr><td>①~⑤ total</td><td>64.0</td></tr> <tr><td>①~⑨ total</td><td>94.0</td></tr> </tbody> </table>	Weight (tons)		①	18.5	②	18.6	③	9.8	④	7.5	⑤	9.6	⑥	6.2	⑦	7.8	⑧	8.0	⑨	8.0	①~⑤ total	64.0	①~⑨ total
Weight (tons)																												
①	18.5																											
②	18.6																											
③	9.8																											
④	7.5																											
⑤	9.6																											
⑥	6.2																											
⑦	7.8																											
⑧	8.0																											
⑨	8.0																											
①~⑤ total	64.0																											
①~⑨ total	94.0																											
<p>①-⑤ : standard 150ton specification : ⑥-⑨ : additional weight (optional)</p>																												
Crane attachment	Inner boom (With boom limit stop)	3.1	1	7.75×2.65×2.4																								
	Outer boom (With pendant rope)	3.4	1	11.3×2.45×2.35																								
	3m insert boom (with pendant rope)	0.85	As required	3.15×2.45×2.35																								
	6m insert boom (with pendant rope)	1.35	As required	6.15×2.45×2.35																								
	9m insert boom (with pendant rope)	1.8	As required	9.15×2.45×2.35																								
	Equalizer	0.8	1	2.27×1.14×0.36																								
	Inner jib (With jib strut pendant rope)	1.1	1	6.95×1.35×1.05																								
	Outer jib (With pendant rope)	0.5	1	6.85×1.07×1.05																								
	1m aux. jib	0.35	1	1.99×0.64×0.4																								
	6m insert jib (with pendant rope)	0.25	As required	6.1×0.98×1.05																								
	150ton hook	2.4	1	0.94×2.21×0.85																								
	100ton hook	1.4	1	0.73×1.97×0.54																								
	60ton hook	1.2	1	0.8×1.77×0.5																								
	13.5ton hook (shared with luffing jib)	0.6	1	0.46×1.52×0.46																								
Luffing attachment	Inner post (with inner post yoke and stabilizer)	5.3	1	7.75×2.65×2.4																								
	Tower top (with top sheave block)	2.9(3.6)	1	4.86×3.02×2.35																								
	3m insert post (shared with 3m insert boom)	0.95	As required	3.15×2.45×2.35																								
	6m insert post (shared with 6m insert boom)	1.50	As required	6.15×2.45×2.35																								
	9m insert post (shared with 9m insert boom)	2.10	As required	9.15×2.45×2.35																								
	Middle equalizer	0.3	1	1.21×0.76×0.33																								
	Strut	2.6	set	7.42×2.07×1.15																								
	Tower inner jib (with jib limit stop)	1.82	1	9.15×2.57×1.5																								
	Tower outer jib (with pendant rope)	1.1	1	9.4×2.1×1.61																								
	3m tower insert jib (with pendant rope)	0.28	As required	3.1×1.6×1.5																								
	6m tower insert jib (with pendant rope)	0.48	As required	6.1×1.6×1.5																								
	9m tower insert jib (with pendant rope)	0.67	As required	9.1×1.6×1.5																								
	50ton hook (for post operations)	1.0	1	0.8×1.9×0.43																								
	25ton hook (shared with post and jib operations)	1.0	1	0.8×1.61×0.35																								

◆Diagrams shown have been drawn for catalog purposes and may differ from actual products.

◆Specifications are subject to change without notice due to technical improvements or modifications.

OPERATOR ORIENTED DESIGN ENSURES SAFE AND EFFECTIVE OPERATION OF GREAT 150-TON

Highest rope speeds in this class 110 meter/minute Load Hoist/Lowering

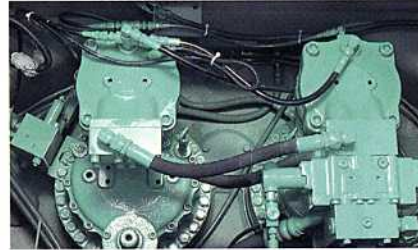

● Powerful Swing

Powerful double-hydraulic-motor for swing motion is independent from all other operations.

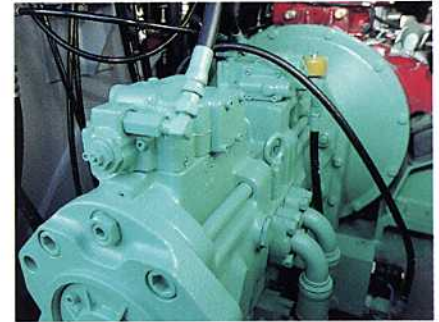

● Full Power-Efficient Hydraulic Control System

Two variable displacement pumps and one gear pump incorporated into engine provide the most effective usage of engine output. Hydraulic flow and pressures are automatically regulated to deliver high flow and low pressure for lighter loads, low flow and high pressure under heavy loading.

Hydraulic Motors to drive main drum, auxiliary drum, the third drum and boom hoist/lowering drum are independently controlled to match each operating speeds. (The third drum is optional for application other than the luffing jib crane)

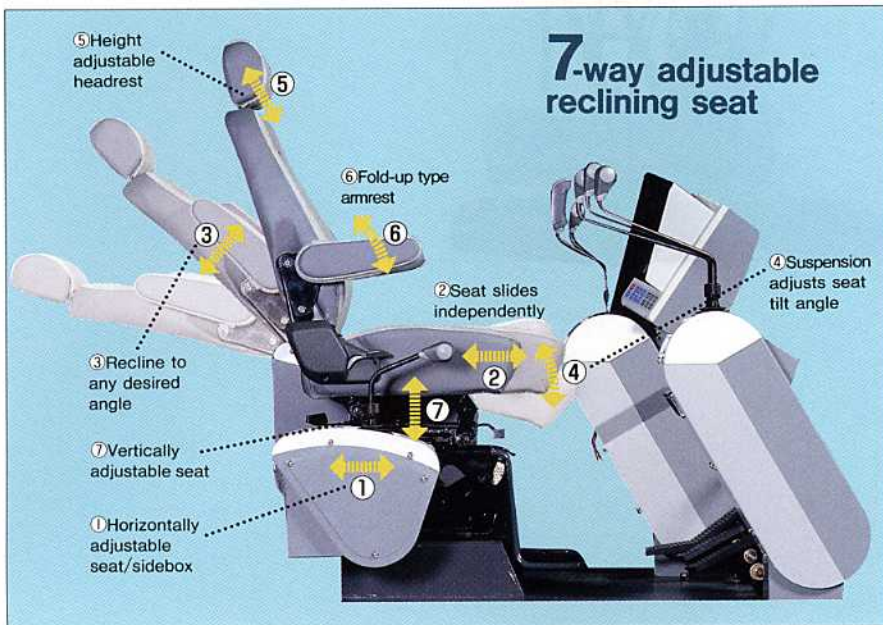

● Dial system controller

Hydraulic pump delivery volume is controlled in conjunction with engine speed supplemented by and independent swash-plate angle control dial. The device provides easy, accurate and precise inching work.



● Wide visibility and deluxe control stands

Dazzle free front glass, radio, intermittent windshield wiper, sunshade, stowbox are standard equipped. Levers, pedals, switches are logically located for safe and easy operation. Engine throttle switch is integrated on swing lever grip. Winch mode switch (select foot or automatic) is located on main and aux. hoist levers.





CCH1500-5
With additional counterweight
(optional)



IHI Construction Machinery Limited

9-7, Yaesu 2-chome, Chuo-ku, Tokyo 104-8480, Japan
Phone: 81-3-3277-3974 Fax: 81-3-3277-3960,4410

Specifications are subject to change without notice due to technical improvements or modifications.
Distributed by



REGISTERED FIRM
NO.0124-ISP 9001